

**Agilent B1542A
Pulsed IV Package for
B1500A/EasyEXPERT**

User's Guide



Agilent Technologies

Notices

© Agilent Technologies, Inc. 2006, 2007, 2008, 2009, 2011, 2012

No part of this manual may be reproduced in any form or by any means (including electronic storage and retrieval or translation into a foreign language) without prior agreement and written consent from Agilent Technologies, Inc. as governed by United States and international copyright laws.

Manual Part Number

B1542-90000

Edition

Edition 1, July 2006
Edition 2, September 2006
Edition 3, February 2007
Edition 4, June 2007
Edition 5, July 2008
Edition 6, October 2009
Edition 7, October 2011
Edition 8, February 2012

Agilent Technologies, Inc.
5301 Stevens Creek Blvd
Santa Clara, CA 95051 USA

Warranty

The material contained in this document is provided “as is,” and is subject to being changed, without notice, in future editions. Further, to the maximum extent permitted by applicable law, Agilent disclaims all warranties, either express or implied, with regard to this manual and any information contained herein, including but not limited to the implied warranties of merchantability and fitness for a particular purpose. Agilent shall not be liable for errors or for incidental or consequential damages in connection with the furnishing, use, or performance of this document or of any information contained herein. Should Agilent and the user have a separate written agreement with warranty terms covering the material in this document that conflict with these terms, the warranty terms in the separate agreement shall control.

Technology Licenses

The hardware and/or software described in this document are furnished under a license and may be used or copied only in accordance with the terms of such license.

Restricted Rights Legend

If software is for use in the performance of a U.S. Government prime contract or sub-contract, Software is delivered and licensed as “Commercial computer software” as defined in DFAR 252.227-7014 (June 1995), or as a “commercial item” as defined in FAR 2.101(a) or as “Restricted computer software” as defined in FAR 52.227-19 (June 1987) or any equivalent agency regulation or contract clause. Use, duplication or disclosure of Software is subject to Agilent Technologies’ standard commercial license terms, and non-DOD Departments and Agencies of the U.S. Government will receive no greater than Restricted Rights as

defined in FAR 52.227-19(c)(1-2) (June 1987). U.S. Government users will receive no greater than Limited Rights as defined in FAR 52.227-14 (June 1987) or DFAR 252.227-7015 (b)(2) (November 1995), as applicable in any technical data.



This product complies with the WEEE Directive (2002/96/EC) marking requirements. The affixed label indicates that you must not discard this electrical/ electronic product in domestic household waste.

Product Category: With reference to the equipment types in the WEEE Directive Annex I, this product is classed as a "Monitoring and Control instrumentation" product.

Do not dispose in domestic household waste.

To return unwanted products, contact your local Agilent office, or see www.agilent.com/environment/product/ for more information.

In This Manual

This manual provides the information about Agilent Technologies B1542A and consists of the following chapters.

- Chapter 1, “Introduction”
Describes product overview of Agilent B1542A.
- Chapter 2, “Installation”
Explains how to install Agilent B1542A.
- Chapter 3, “Performing System Setup and Compensation”
Explains how to perform system setup and how to update compensation data.
- Chapter 4, “Performing Measurement”
Describes measurement examples by using the pulsed IV test system.
- Chapter 5, “PLSDIV Test Definitions”
Provides reference information for application test definitions (PLSDIV test definitions) used for the pulsed IV measurement.
- Chapter 6, “PLSDIV TIS Commands”
Provides reference information for execution files (Plsdiv commands, PLSDIV TIS) used in the PLSDIV test definitions.
- Chapter 7, “Status Code and Error Messages”
Lists the status code and the error messages.

NOTE

The pulsed IV test system consists of some instruments, oscilloscope, pulse generator, source monitor unit, and so on. To use the instruments independently or for details of the instruments, see the manual of each instrument.

NOTE

To get the latest firmware/software/manual/support information, go to www.agilent.com and type in B1542A in the Search field at the top of the page.

Contents

1. Introduction

Overview	1-3
System Hardware	1-3
System Software.....	1-5
Typical Technical Information.....	1-6
Accessories and Options	1-7

2. Installation

Inspection	2-3
RF Probes	2-4
DC Probes	2-5
Hardware Installation.....	2-6
Installing Instruments.....	2-6
Connecting Interface Cables	2-7
Installing Pulsed IV Test System	2-8
Connecting RF Probes	2-13
Connecting DC Probes	2-14
Software Installation	2-16
System Requirements.....	2-17
Installing Software	2-17
Installing Cable Compensation Data	2-17
After Software Installation.....	2-18
Updating Software	2-19
Removing Pulsed IV Software	2-19
Rack-mounting Instruments.....	2-20
Rack-mounting Pulse/dc Switch Units	2-21

3. Performing System Setup and Compensation

Contents

Pulsed IV System Setup	3-3
Starting System Setup	3-6
If You Use DSO/MSO9000A Series Oscilloscope	3-7
If You Use External Computer.	3-8
System Configuration	3-10
LAN Setup for DSO Control Dialog Box.	3-10
SMU CH for Compensation Dialog Box	3-11
Executing Action.	3-12
Compensation Action	3-13
Pgu Compensation Action	3-13
4. Performing Measurement	
Theory of Measurement	4-3
Terminal Voltage and Source Output Value.	4-4
Before Measurement	4-5
Performing System Reset.	4-6
Pulse Waveform Measurement	4-7
Pulsed Id-Vd Measurement	4-9
Pulsed Id-Vg Measurement	4-11
DC I-V Measurements.	4-13
5. PLSDIV Test Definitions	
PLSDIV Capt Wave	5-4
PLSDIV DC IdVd	5-7
PLSDIV DC IdVd SMU.	5-10
PLSDIV DC IdVg	5-13

Contents

PLSDIV DC IdVg SMU	5-16
PLSDIV IdVd, PLSDIV IdVd [2]	5-19
PLSDIV IdVg, PLSDIV IdVg [2]	5-23
PLSDIV IV SMU.	5-27
PLSDIV Reset	5-31
PLSDIV Setup	5-32
Parameters	5-34

6. PLSDIV TIS Commands

Command Summary	6-3
Entering Plsdiv Commands	6-5
Command Parameters	6-5
Defining Numeric/Vector Input Parameter	6-6
Defining String/Numeric Input Parameters	6-6
Defining Numeric Output Parameter	6-6
Defining Vector Output Parameter	6-7
Defining String Output Parameter	6-7
Defining Format Field	6-7
Setup Example	6-8
Command Reference	6-9
DispMessage	6-10
PlsdivCaptureMonData	6-11
PlsdivCaptureTimeData	6-12
PlsdivCutoffVd	6-13
PlsdivCutoffVg	6-13
PlsdivErrorMessage	6-13
PlsdivForceVd	6-14
PlsdivForceVg	6-14

Contents

PlsdivInit	6-15
PlsdivMeasureId	6-17
PlsdivSetAdjustStat	6-18
PlsdivSetAveraging	6-18
PlsdivSetDeviceDelay	6-19
PlsdivSetMeasTime	6-20
PlsdivSetPulseWidth	6-21
PlsdivSetSampling	6-21
PlsdivSetSmoothing	6-22
PlsdivSetTransTime	6-23
PlsdivSetVgLevel	6-23
PlsdivUninit	6-24

7. Status Code and Error Messages

1 **Introduction**

Introduction

Agilent B1542A Pulsed IV Package for B1500/EasyEXPERT is a solution package for the Agilent B1500A or Desktop EasyEXPERT users and provides the automated pulsed IV test environment. This chapter introduces Agilent B1542A, and consists of the following sections.

- “Overview”
- “Typical Technical Information”
- “Accessories and Options”

Overview

Agilent B1542A Pulsed IV Package expands the capabilities of Agilent B1500A Semiconductor Device Analyzer to enable the ultra short pulsed IV measurements with parametric characterization down to 10 ns pulse width for many new device structures such as silicon-on-insulator (SOI) transistors that are more susceptible to harmful thermal effects during characterization.

Using the B1542A, you can easily and effectively configure the pulsed IV test system and perform the pulsed IV measurement of MOSFET on the Agilent EasyEXPERT or Desktop EasyEXPERT application test environment.

The B1542A supports the B1500A as the DC source monitor. And the B1542A additionally supports the Agilent 4155B/4155C/4156B/4156C Semiconductor Parameter Analyzer and the Agilent E5260/E5270 Series of Parametric Measurement Solutions by using the Desktop EasyEXPERT software.

System Hardware

The pulsed IV test system can be configured by using the following equipment. See Figure 1-1. The B1542A provides the accessories used to connect the equipment.

- Agilent B1500A Semiconductor Device Analyzer
- Oscilloscope, minimum two measurement channels, see Table 1-1
- Pulse Generator, minimum one output channel, see Table 1-2
- Switch Controller and Pulse/dc Switch Units, furnished with the B1542A
- Windows PC installed with Desktop EasyEXPERT

Optional for the system with the B1500A. Absolute necessity for the system with the following instrument.

- Agilent 4155B/C Semiconductor Parameter Analyzer
- Agilent 4156B/C Precision Semiconductor Parameter Analyzer
- Agilent E5260A/E5270B Measurement Mainframe

The pulsed IV system uses 3 channels of SMU. So Agilent E5262A/E5263A 2-channel SMU is not recommended. However it may be used if you change the connections manually. Because the pulsed IV measurement uses one SMU and the DC IV measurement uses only 2 ea. of SMU.

Table 1-1 Oscilloscope Supported by Agilent B1542A

Agilent Model Number	Remarks
54853A/54854A/54855A	2.5/4/6 GHz, 4 channels, 20 GSa/s
DSO8000A series MSO8000A series	600 MHz or 1 GHz, 4 channels, 4 GSa/s
DSO80000B series	2/3/4/6/8/10/12/13 GHz, 4 channels, 40 GSa/s when using 1 or 2 channels, 20 GSa/s when using all channels
DSO9104A/9254A/9404A MSO9104A/9254A/9404A	1/2.5/4 GHz, 4 channels, 20 GSa/s
DSO90254A/90404A/90604A	2.5/4/6 GHz, 4 channels, 20 GSa/s

Table 1-2 Pulse Generator Supported by Agilent B1542A

Agilent Model Number	Remarks
81101A	50 MHz output, standalone
8110A with 81103A	150 MHz output, modular
81110A with 81111A	165 MHz output, modular
81150A	120 MHz output, standalone

Figure 1-1 Pulsed IV Test System by Using Agilent B1542A

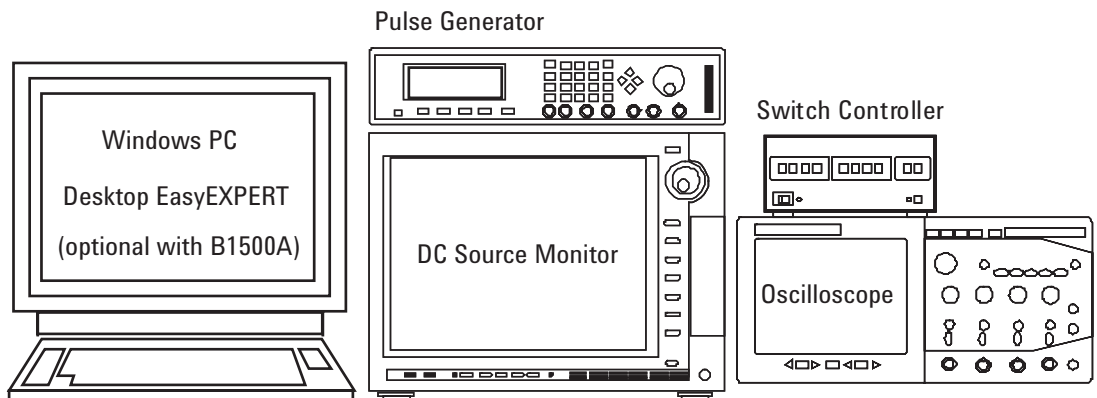

System Software

The B1542A supports the pulsed IV measurement applications listed below. The programs used to perform the measurement are provided as the EasyEXPERT application test definition. Therefore the pulsed IV measurement can be performed easily on the EasyEXPERT or Desktop EasyEXPERT application test environment without creating the test programs. The B1542A also provides the test definition used for the system setup.

- Pulsed IV Id-Vd characteristics measurement
- Pulsed IV Id-Vg characteristics measurement
- Pulsed IV waveform measurement
- DC Id-Vd characteristics measurement for B1500A
- DC Id-Vg characteristics measurement for B1500A
- Pulsed IV system reset
- Pulsed IV system setup
- DC I-V sweep measurement for 4155/4156/E5260/E5270
- DC Id-Vd characteristics measurement for 4155/4156/E5260/E5270
- DC Id-Vg characteristics measurement for 4155/4156/E5260/E5270

Typical Technical Information

The followings are the typical technical information of the pulsed IV test system configured by Agilent B1542A. Those are not the specifications but the typical and supplemental data the test system can provide.

Gate pulse width: 10 ns to 1 μ s

Gate pulse voltage: -4.5 V to 4.5 V

Gate pulse base line voltage: -3.0 V to 3.0 V

Gate pulse amplitude: maximum 4.5 V

Gate pulse period: 100 μ s

Drain pulse maximum measurement current: 80 mA

Drain pulse current measurement resolution: 1 μ A

Drain voltage range: -10 V to 10 V

Accessories and Options

Table 1-3 lists the available options for Agilent B1542A. And Table 1-4 lists the contents of the B1542A.

Table 1-3

Options

Model Number	Description
R1280A	Return-to-Agilent - warranty and service plan
R1282A	Return-to-Agilent calibration plan

Table 1-4

Contents

Description		Quantity
Software license to use, media, and manual		
	Pulsed IV package software CD-ROM	1
	Drain cable compensation data CD-ROM	1
	Desktop EasyEXPERT software CD-ROM	1
	User's Guide, English	1
Drain cable set		
	Triaxial cable, 1.5 m	1
	BNC(m)-Triax(f) adapter, floating guard	1
	SMA(f)-BNC(m) adapter, precision type	1
	SMA cable, 30 cm	1
	DUT cable, 1.5 m	1
	Magnet sheet (for fixing the bias-T)	1

Introduction
Accessories and Options

Description		Quantity
Gate cable set		
	SMA(f)-BNC(m) adapter	1
	SMA cable, 30 cm	1
	SMA(f)-BNC(m) adapter, precision type	1
	SMA cable, 1.5 m	1
	DUT cable, 1.5 m	1
	SMA (f)-(m)-(f) adapter	1
	Terminator, dc-26.5 GHz, 3.5 m with option 011	1
	SMA(m)-SMA(m) adapter	1
	Magnet sheet (for fixing the divider)	1
Docking interface		
	BNC cable, 1.5 m	2
	Triaxial cable, 1.5 m	1
	GNDU-chassis adapter	1
	Triaxial cable, 1.5 m	1
	BNC(m)-(f)-(f) adapter	1
	BNC(m)-Triax(f) adapter, floating guard	1
	GPIB cable, 1 m	2
	Torque wrench, 5 lb.	1
	Torque wrench, 8 lb.	1
	Open-end wrench, 5/16 inch	1
	Open-end wrench, 11/32 inch	1

Description		Quantity
Pulse/dc switch set		
	Switch controller	1
	Switch control cable (viking cable, D-sub 15 pin)	1
	Switch control distributor	1
	Drain pulse/dc switch unit	1
	Gate pulse/dc switch unit	1
	Triaxial cable, 1.5 m	2
	D-sub 9 pin cable, 3 m	2
	Wrench, T10	1
	GPIB cable, 1 m	1
Rack-mount kit for pulse/dc switch units		
	Panel	1
	Rail kit for pulse/dc switch units	1
	Rail kit for pulse/dc switch units	1
	Support rail for rack-mounting oscilloscope (7 EIA maximum) onto Agilent 1181B testmobile system cart	2
	Screw	12
	Screw	2
	Nut	8
	Wire	3
	Screw	8
Pulsed IV DC probe cable set		
	SMA(f)-SSMC cable	1
	SMA(m)-SSMC cable	1
	SSMC short-open cable, 50 mm	2
	SSMC short-open cable, 75 mm	2

Introduction
Accessories and Options

2

Installation

Installation

This chapter describes the inspection and installation instructions of Agilent B1542A pulsed IV package for B1500A/EasyEXPERT, and consists of the following sections. To perform the pulsed IV measurement, complete the hardware and software installation described in this chapter.

- “Inspection”
- “RF Probes”
- “DC Probes”
- “Hardware Installation”
- “Software Installation”
- “Rack-mounting Instruments”

If you rack-mount the pulse/dc switch units, see “Rack-mounting Instruments” on page 2-20 which describes how to install the rack-mount kit for the pulse/dc switch units. After you complete the rack-mounting, see “Hardware Installation” on page 2-6 to install the system equipment.

CAUTION**Using Torque Wrench and Open-end Wrench**

For the RF measurements, it is important to carefully contact and fasten the connectors of the RF cables. The condition of the cable connections may change the measurement result characteristics. Therefore treat the RF cables carefully, especially the RF connectors, and use the torque wrench and the open-end wrench when you fasten the RF connectors. The wrenches are furnished with the B1542A.

CAUTION**Using Cable Tie**

Use a cable tie to secure the cables. Then, do not tug the cable tie. You must treat the RF cables carefully to avoid the damage.

NOTE**Using Magnet Sheet**

Use a magnet sheet to fix the divider or the bias-T to a metal plate. The magnet sheet is furnished with the B1542A.

Inspection

Perform the following inspections when the B1542A arrives at your site.

1. Before unpacking any components, inspect all boxes for any sign of damage that might have occurred during shipment, such as:
 - dents
 - scratches
 - cuts
 - water marks

If you suspect any damage, notify your local Agilent Technologies sales or service office.

2. When you open the boxes containing the B1542A, check the components against the contents lists attached to the boxes. See also Table 1-4.

If anything is missing, notify your local Agilent Technologies sales or service office.

RF Probes

The pulsed IV test system supports the measurement of the three-terminal MOSFET (source and well (substrate) are shorted). And its measurement path must be extended to the RF probes as shown in Figure 2-1 to achieve 10 nsec minimum pulse width. One measurement path is for the gate terminal and the other path is for the drain terminal. Moreover the source/well terminal must be electrically connected to the ground via the shielding of the measurement path (RF probes and measurement cables). See Figure 2-2.

Figure 2-1

RF Probe Connection

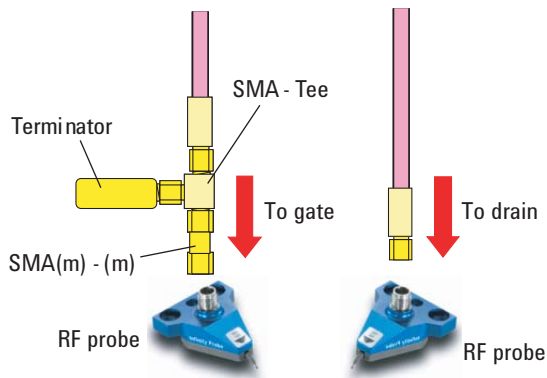

Prepare two RF probes to perform the pulsed IV measurement. The RF probe must have the signal line and the ground lines as shown in Figure 2-2. The signal line is to contact the gate or drain pad, and the ground lines are to contact the source/well pads. For the RF probe and its installation, consult your favorite prober vender. Figure 2-1 shows the RF probes of Cascade Microtech, Inc.

Figure 2-2

Contact Pad and Probe Tip

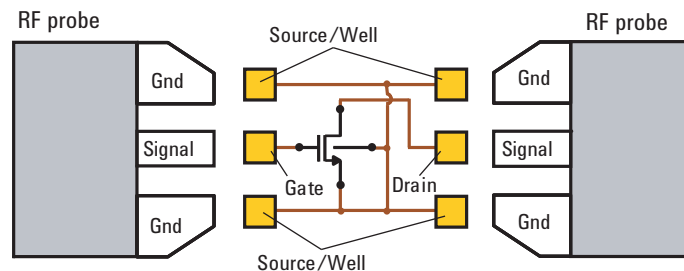

DC Probes

The MOSFET contact pads for DC measurement shown in Figure 2-3, are more popular than the RF contact pads shown in Figure 2-2. If device under test is configured with DC contact pads, use DC probes instead of RF probes. The DC probes are better suited for contact with the DC contact pads than the RF probes. See Figure 2-3 for the contact pads and the DC probes. Required cables for connecting the DC probes are furnished with the B1542A as the DC probe cable set. For more information, see “Connecting DC Probes” on page 2-14.

When using DC probes, minimum pulse width should be limited to approximately 60 nsec to 100 nsec.

Figure 2-3 Contact Pad and DC Probe Connection

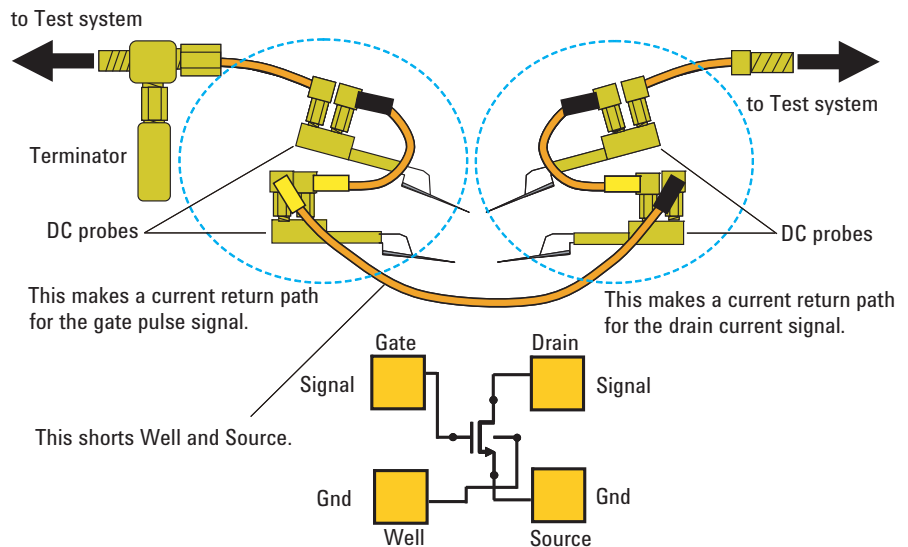

Hardware Installation

This section describes the instructions to install the B1542A. The installation instructions cover the connection of the control cables and the connection of the measurement cables to the RF or DC probes used to contact the device under test (MOSFET). The connection overview of the pulsed IV test system is shown in Figure 2-5.

- “Installing Instruments”
- “Connecting Interface Cables”
- “Installing Pulsed IV Test System”
- “Connecting RF Probes”
- “Connecting DC Probes”

Installing Instruments

The pulsed IV test system uses the DC source monitor, pulse generator, oscilloscope, and switch controller with switch units. Install the instruments to the appropriate place. See Figure 2-4 for example. For more information, see the manual of each instrument. It provides the required environment and the necessary and unique information for the instrument.

Figure 2-4

Installing Instruments

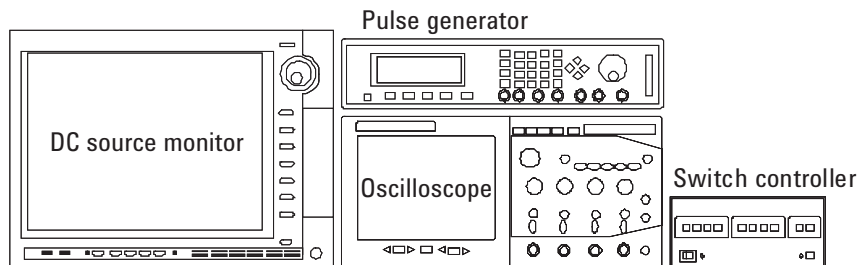

Connecting Interface Cables

Connect the instruments via GPIB or LAN as shown below.

Requirements:

- GPIB cable, maximum 4 ea. Quantity depends on your system components (instruments and computer).
- LAN cable, 2 ea. only for using the DSO/MSO9000 series oscilloscope

Procedure:

1. Connect a GPIB cable between the DC source monitor and the pulse generator.
2. Connect a GPIB cable between the switch controller and one of above instruments.
3. For the Desktop EasyEXPERT users:
Connect a GPIB cable between your computer and one of above instruments.
4. Connect the oscilloscope as shown below.

- For using the DSO/MSO9000 series oscilloscope:

- a. Connect the B1500A or your computer to a LAN.
- b. Connect the oscilloscope to the LAN.

Subnet mask must be the same for their network settings.

- For using the other oscilloscope:

Connect a GPIB cable between the oscilloscope and one of above instruments or computer.

Installing Pulsed IV Test System

The connection overview of the pulsed IV test system is shown in Figure 2-5. To install the system, perform the following steps.

1. “Connecting Switch Controller” on page 2-10
2. “Making Measurement Path for Gate” on page 2-11
3. “Making Measurement Path for Drain” on page 2-12
4. “Connecting RF Probes” on page 2-13 or “Connecting DC Probes” on page 2-14

Figure 2-5 Pulsed IV Test System Connection Overview

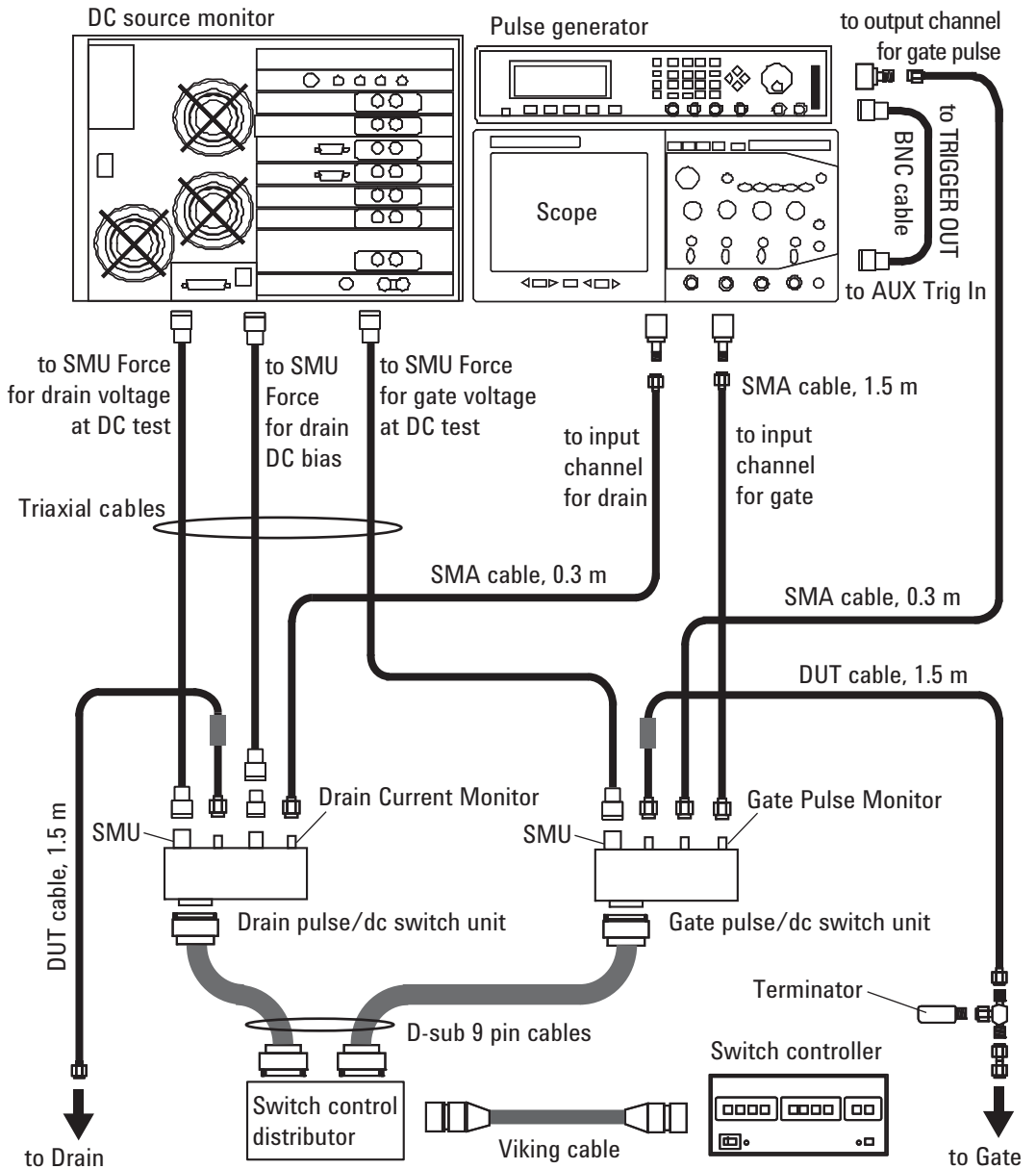

Connecting Switch Controller

1. Install the switch controller and connect the GPIB cable. See “Installing Instruments” and “Connecting Interface Cables” on page 2-7.
2. Fix the switch control distributor to the appropriate place.
3. Connect the viking cable between the switch controller and the switch distributor.
4. Connect the D-sub 9 pin cable between the switch distributor Switch 1 connector and the gate pulse/dc switch unit.
5. Connect the D-sub 9 pin cable between the switch distributor Switch 2 connector and the drain pulse/dc switch unit.

Required accessories and equipment:

- Viking cable, 1 ea.
- D-sub 9 pin cable, 2 ea.
- Switch Controller, 1 ea.
- Switch Control Distributor, 1 ea.
- Gate Pulse/dc Switch Unit with divider, 1 ea.
- Drain Pulse/dc Switch Unit with bias-T, 1 ea.

Figure 2-6

Switch Controller, Switch Control Distributor, and Pulse/dc Switch Units

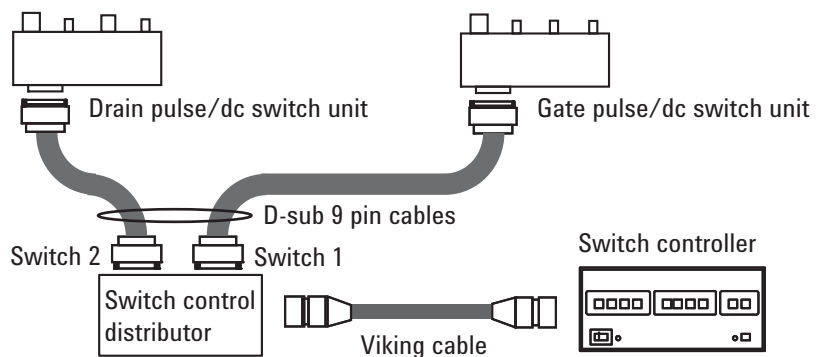

Making Measurement Path for Gate

Connect the following accessories as shown in Figure 2-7. And fix the gate pulse/dc switch unit to the appropriate place. Use a torque wrench and an open-end wrench to fasten the SMA connectors.

Required accessories:

- BNC(m)-SMA(f) adapter, 1 ea., for pulse generator
- BNC(m)-SMA(f) adapter, precision type, 1 ea., for oscilloscope
- BNC cable, 1 ea.
- SMA cable, 0.3 m, 1 ea.
- SMA cable, 1.5 m, 1 ea.
- Triaxial cable, 1 ea.

Figure 2-7

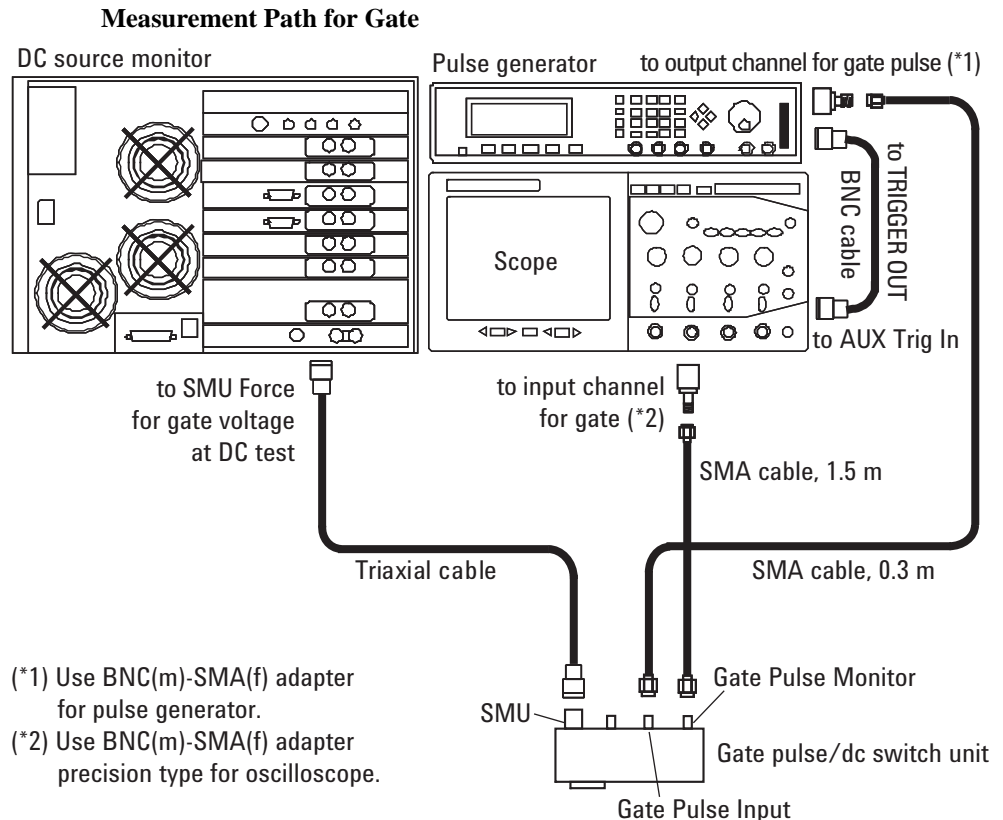

Making Measurement Path for Drain

Connect the following accessories as shown in Figure 2-8. And fix the drain pulse/dc switch unit to the appropriate place. Use a torque wrench and an open-end wrench to fasten the SMA connectors.

Required accessories:

- BNC(m)-SMA(f) adapter, precision type, 1 ea., for oscilloscope
- SMA cable, 0.3 m, 1 ea.
- BNC(m)-Triax(f) adapter, floating guard, 1 ea.
- Triaxial cable, 2 ea.

Figure 2-8

Measurement Path for Drain

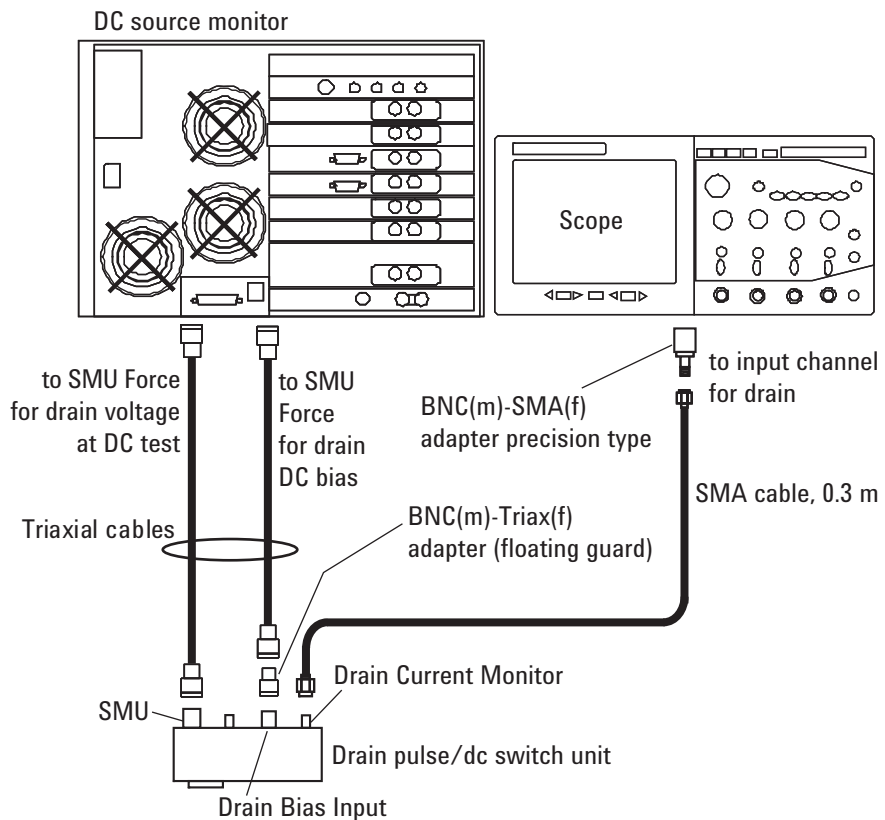

Connecting RF Probes

Only for the RF probe users. Connect the following accessories as shown in Figure 2-9. Use a torque wrench and an open-end wrench to fasten the SMA connectors.

Required accessories:

- DUT cable, 1.5 m, 2 ea.
- SMA(f)-(m)-(f) adapter, 1 ea.
- 50 Ω Terminator, 1 ea.
- SMA(m)-(m) adapter, 1 ea., used to connect the path to the RF probe for gate

Procedure:

1. Connect a DUT cable between a RF probe and the bias-T's RF+DC connector or the Drain pulse/dc switch unit's DUT connector of the pulsed IV test system. And set the RF probe to the appropriate place.
2. Connect the SMA adapters, terminator, and a DUT cable between a RF probe and the divider or the Gate pulse/dc switch unit's DUT connector of the pulsed IV test system. And set the RF probe to the appropriate place.

Figure 2-9

RF Probe Connections

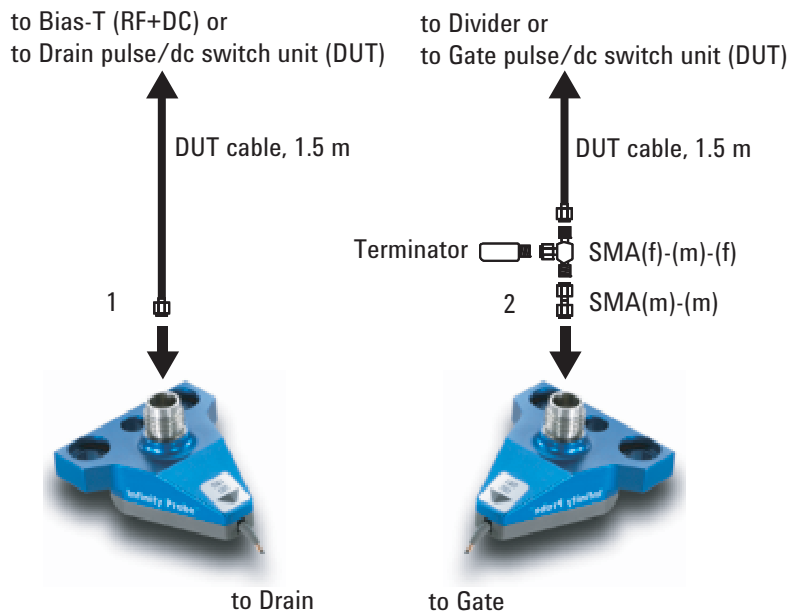

Connecting DC Probes

Only for the DC probe users. Connect the following accessories as shown in Figure 2-10. Use a torque wrench and an open-end wrench to fasten the SMA connectors.

Required accessories:

- DUT cable, 1.5 m, 2 ea.
- SMA(f)-(m)-(f) adapter, 1 ea.
- 50 Ω Terminator, 1 ea.
- SMA(m)-SSMC cable, 1 ea. (part of the pulsed IV DC probe cable set)
- SMA(f)-SSMC cable, 1 ea. (part of the pulsed IV DC probe cable set)
- SSMC short-open cable, 3 ea. (parts of the pulsed IV DC probe cable set)

50 mm or 75 mm cable length. Use appropriate one. For the external view and the internal connection, see Figure 2-11.

Figure 2-10 DC Probe Connections

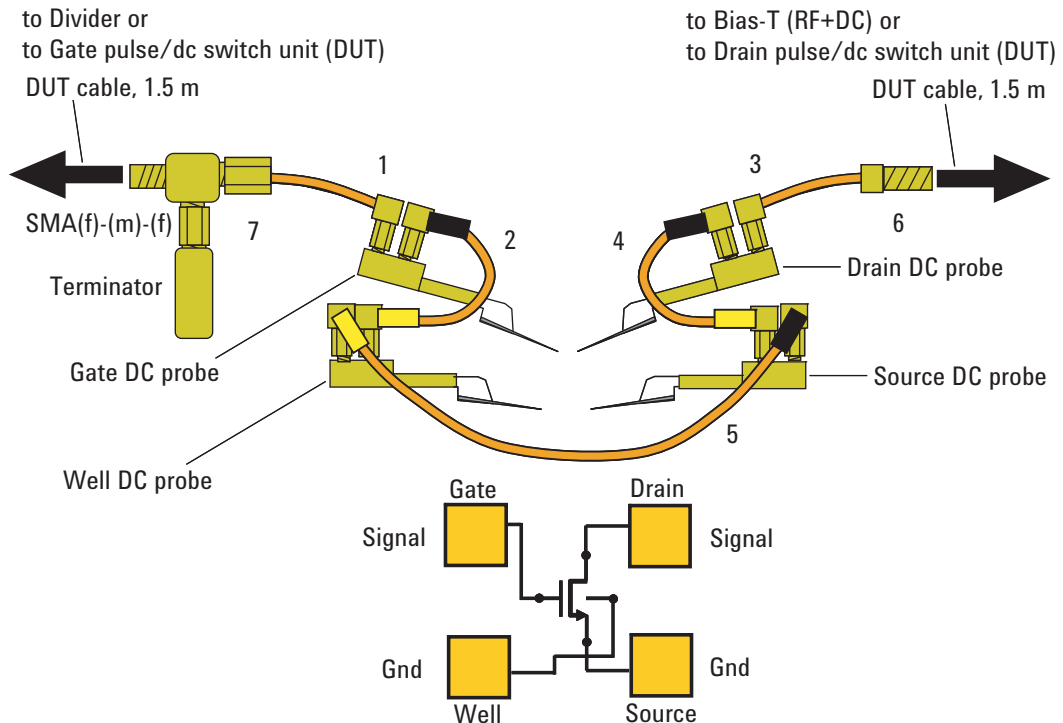

Procedure:

1. Connect the SMA(m)-SSMC cable to the Gate DC probe.
2. Connect a SSMC short-open cable between the Gate DC probe and the Well DC probe, and set the DC probe to the appropriate place. Then, the black sleeve plug must be the Gate side. This electrically connects the Well probe needle, Well probe shield, and Gate probe shield together.
3. Connect the SMA(f)-SSMC cable to the Drain DC probe, and set the DC probe to the appropriate place.
4. Connect a SSMC short-open cable between the Drain DC probe and the Source DC probe, and set the DC probe to the appropriate place. Then, the black sleeve plug must be the Drain side. This electrically connects the Source probe needle, Source probe shield, and Drain probe shield together.
5. Connect a SSMC short-open cable between the Well DC probe and the Source DC probe, and set the DC probe to the appropriate place. Then, the black sleeve plug must be the Source side. This electrically connects the Well probe needle, Well probe shield, and Source probe shield together.
6. Connect a DUT cable between the Drain DC probe's SMA(f) connector and the bias-T's RF+DC connector or the Drain pulse/dc switch unit's DUT connector of the pulsed IV test system.
7. Connect the SMA(f)-(m)-(f) adapter, terminator, and a DUT cable between the Gate DC probe's SMA(m) connector and the divider or the Gate pulse/dc switch unit's DUT connector of the pulsed IV test system.

Figure 2-11

SSMC Short-Open Cable

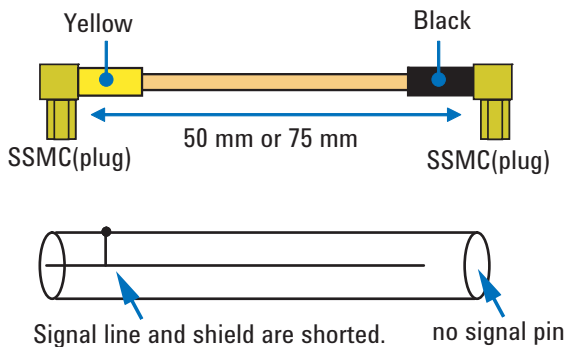

Software Installation

This section describes the instructions to install the pulsed IV system software.

- “System Requirements”
- “Installing Software”
- “Installing Cable Compensation Data”
- “After Software Installation”
- “Updating Software”
- “Removing Pulsed IV Software”

To install the pulsed IV system software, perform the instructions described in “Installing Software”, “Installing Cable Compensation Data”, and “After Software Installation” in this order.

To update the pulsed IV system software, perform the instruction described in “Updating Software”.

NOTE

This section uses the following conventions.

<system drive>: Drive the pulsed IV system software is installed

<program folder>: Following folder

For Windows 7 64 bit version, <system drive>:\Program Files (x86)

For B1500A, Windows 7 32 bit version, and Windows XP,

<system drive>:\Program Files

<data folder>: Following folder

For Windows 7, <system drive>:\Program Data

For Windows XP, <system drive>:\Documents and Settings\All Users\Application Data

System Requirements

The pulsed IV system software is allowed to be installed in the one of the following system controller.

- Agilent B1500A installed with EasyEXPERT software
- Windows PC installed with Desktop EasyEXPERT software

If the B1500A is used as the DC source monitor, the revision number of Desktop EasyEXPERT must be the same as the EasyEXPERT installed in the B1500A.

NOTE

To install the pulsed IV system software, you must log on to Windows as an administrator.

Installing Software

Install the pulsed IV system software as shown below.

1. Exit EasyEXPERT software or Desktop EasyEXPERT software. If the Start EasyEXPERT window is opened, close it.
2. Insert the Pulsed IV package software CD-ROM into the disk drive.
3. Execute the setup.exe in the CD-ROM.
4. Follow the instructions of the setup wizard. And wait until the program installation is completed.
5. After the installation, remove the CD-ROM from the disk drive.

Installing Cable Compensation Data

Install the drain cable compensation data as shown below.

1. If the Start EasyEXPERT window is opened, close it first.
2. Insert the Drain cable compensation data CD-ROM into the disk drive.
3. Execute the following file in the CD-ROM.
`\\DrainSetup\drain_setup.msi`
4. Follow the instructions of the setup wizard. And wait until the data installation is completed.
5. After the installation, remove the CD-ROM from the disk drive.

After Software Installation

1. Launch EasyEXPERT or Desktop EasyEXPERT. And click the Start EasyEXPERT button.
2. Open your workspace or create a new workspace.
3. Display the Application Test tab screen.
4. Import the pulsed IV test definitions listed below from the following folder.
<program folder>\Agilent\PLSDIV\TestDefinitions\Import1st
 - PLSDIV IdVd
 - PLSDIV IdVd [2]
 - PLSDIV IdVg
 - PLSDIV IdVg [2]
 - PLSDIV DC IdVd
 - PLSDIV DC IdVg
 - PLSDIV Capt Wave
 - PLSDIV Setup
 - PLSDIV Reset
 - PLSDIV IV SMU
5. Import the pulsed IV test definitions listed below from the following folder.
<program folder>\Agilent\PLSDIV\TestDefinitions\Import2nd
 - PLSDIV DC IdVd SMU
 - PLSDIV DC IdVg SMU
6. Open the PLSDIV Setup test definition and perform the system setup as described in Chapter 3, “Performing System Setup and Compensation.”

Updating Software

Perform the following procedure to update the pulsed IV system software.

1. Launch EasyEXPERT or Desktop EasyEXPERT. And click the Start EasyEXPERT button.
2. Open your workspace.
3. Display the Application Test tab screen.
4. Remove checks from categories except for the Pulsed IV in the Category list.
5. Right-click a pulsed IV test definition in the Library list and click Delete Definition of This Test to open the confirmation dialog box. And click OK to delete the test definition from the present workspace.

Repeat this to delete all of the pulsed IV test definitions.

6. Remove the pulsed IV system software now installed. See “Removing Pulsed IV Software” on page 2-19.
7. Install the latest revision of the pulsed IV system software. See “Installing Software” on page 2-17.
8. Install the drain cable compensation data. See “Installing Cable Compensation Data” on page 2-17.
9. Import the pulsed IV test definitions. See “After Software Installation” on page 2-18.

Removing Pulsed IV Software

Perform the following procedure to remove the pulsed IV system software.

1. Exit EasyEXPERT software or Desktop EasyEXPERT software. If the Start EasyEXPERT window is opened, close it.
2. Open the Control Panel.
3. Uninstall the pulsed IV system software.
4. Open the Explorer.
5. Delete the <program folder>\Agilent\PLSDIV folder.
6. Delete the <data folder>\Agilent\PLSDIV folder.

Rack-mounting Instruments

Image of rack mount is shown in Figure 2-12. This figure shows the rack-mount position of the instruments. For rack mounting the instruments, see manual of instrument rack (Agilent E7590A: 1.3 m, E3661B: 1.6 m, E3662B: 2.0 m) and rack-mount kit. For the required parts for rack-mounting oscilloscope, pulse generator, and switch controller, see manual of each instrument.

Figure 2-12

Image of Rack Mount

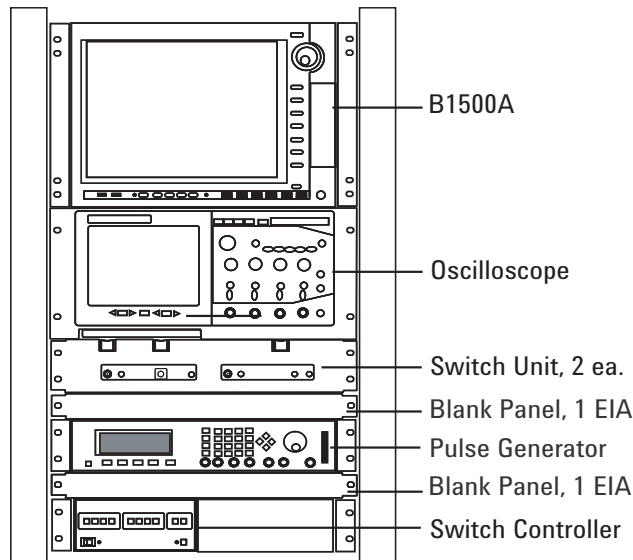

See “Rack-mounting Pulse/dc Switch Units” on page 2-21 for rack-mounting the switch units. The required parts for rack-mounting the switch units and the B1500A are listed in Table 2-1.

Table 2-1

Required Parts for Rack-mounting B1500A and Switch Units

Agilent Model No. or Part No.	Quantity	Description
—	1	Rack-mount kit for pulse/dc switch units, furnished with the B1542A
5063-9218	1	Rack-mount flange kit for B1500A, 7 EIA
E3663AC	1	Support rail kit, for B1500A

Rack-mounting Pulse/dc Switch Units

Rack-mount pulse/dc switch units as shown below. The required parts are furnished with the B1542A. See Figure 2-14.

Required parts:

Reference Designator	Agilent Part No.	Quantity	Description
A	B1542-00201	1	Panel
B	B1542-01211	1	Rail kit
C	B1542-01212	1	Rail kit
-	0515-0372	12	Screw

Procedure:

1. Assemble the rail kits *B* and *C* as shown in Figure 2-13.
2. Secure the rail assemblies *B* and *C* to the proper position of the system rack by using the typical rack-mounting method of the support rail kit.
3. Assemble the pulse/dc switch unit panel by mounting the following units on the panel *A*. Use screws listed above to fix the units.

Reference Designator	Agilent Part No.	Description
D	B1542-60001	Switch control distributor
E	B1542-60002	Drain pulse/dc switch unit
F	B1542-60003	Gate pulse/dc switch unit

4. Align the pulse/dc switch unit panel (*A* with *D*, *E*, and *F*) with the rail assemblies secured to the system rack in the step 2, gently slide the panel on the rails until it stops, and secure the panel to the system rack by using the typical rack-mounting method of the rack-mount flange kit.

Installation
Rack-mounting Instruments

Figure 2-13 Assembling Rail Kit

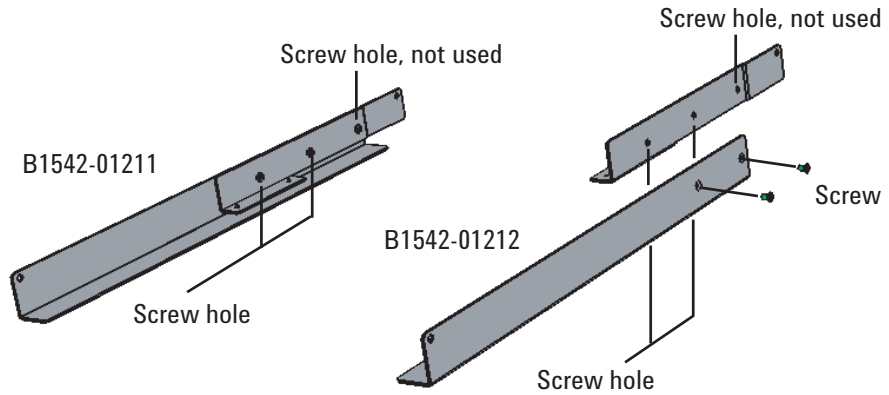
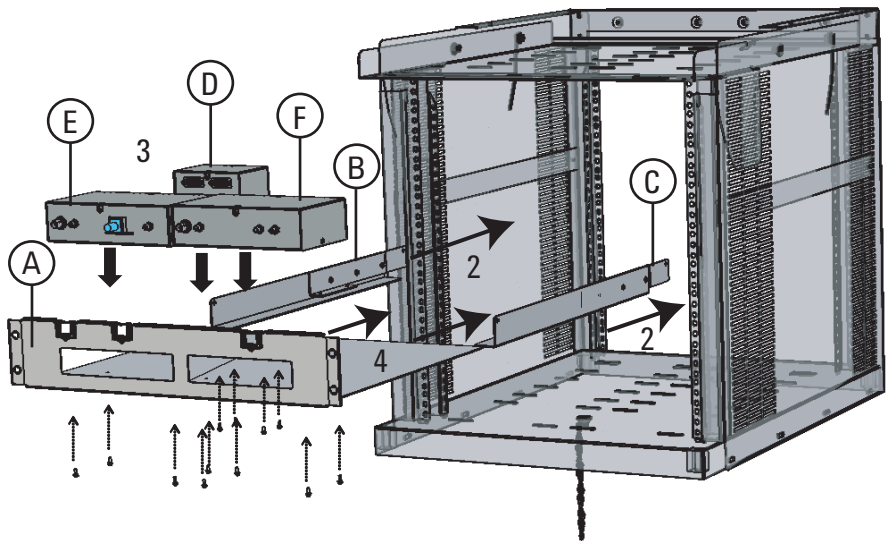

Figure 2-14 Rack-mounting Pulse/dc Switch Units



3 **Performing System Setup and Compensation**

Performing System Setup and Compensation

This chapter describes how to perform system setup and compensation of the pulsed IV test system and consists of the following sections. The system setup can be performed by using the pulsed IV setup (PLSDIV Setup) test definition on the EasyEXPERT application test environment.

- “Pulsed IV System Setup”
- “Starting System Setup”
- “System Configuration”
- “Executing Action”

NOTE**Before Starting System Setup**

The pulsed IV test system must be installed correctly. See Chapter 2, “Installation.” Then do not forget to install the compensation data files.

NOTE**Drain Cable Replacement**

It is inadequate to replace only the defective part when you find any defect in the drain measurement path. The compensation data of the measurement path must be also updated after the replacement.

Order the drain cable set and replace it. After that, perform the compensation data installation. For the cable connection and the compensation data installation, see Chapter 2, “Installation.”

Pulsed IV System Setup

The pulsed IV system setup items are listed below. The system setup must be performed and successfully completed before using the pulsed IV test system.

Accessories needed to perform the system setup are listed in Table 3-1. Prepare the accessories additionally to the system accessories and the system components.

- System Configuration

This action is necessary to specify the interface address and the source or measurement channels of PGU (pulse generator), DSO (digital sampling oscilloscope), and SMU (source monitor unit) used for the pulsed IV measurement. See “System Configuration” on page 3-10. For the setup parameters, see Table 3-3.

- Compensation

This action is necessary to obtain and update the compensation factors of the pulsed IV test system.

- Skew Measurement

This action performs the skew measurement which is one of the measurements performed in the Compensation action. If the skew measurement error occurs during the Compensation action is executed, you can perform only the skew measurement again by this action.

- Drain Cable Replacement

This action is necessary to obtain and update the compensation factors of the bias-T and the cable of the drain measurement path.

- Pgu Compensation

This action obtains the compensation factors of the pulse generator. This action should be executed before you perform the pulsed IV measurements which set the gate voltage automatic adjustment (*VgAdjust*) to off (*Disable*).

When you must perform the system setup is shown in Table 3-2.

To execute an action, see “Executing Action” on page 3-12.

Performing System Setup and Compensation
Pulsed IV System Setup

Table 3-1 Required Accessories to Perform System Setup

Accessory	Quantity
Triaxial cable	2
BNC cable	1
BNC(m)-Triax(f) adapter, floating guard	1
BNC(m)-(f)-(f) adapter	1
GNDU-chassis adapter	1

Table 3-2 Pulsed IV System Setup

When the action must be executed	Action
after system installation	System Configuration
	Compensation
after changing interface address of an instrument	System Configuration
after changing a channel assignment	System Configuration
	Compensation
after repair of oscilloscope	Compensation
after calibration of oscilloscope	Compensation
after replacing oscilloscope	Compensation
after replacing bias-T	Drain Cable Replacement
after replacing measurement cables to drain terminal	Drain Cable Replacement
before starting the pulsed IV measurements with the <i>VgAdjust=Disable</i> condition	Pgu Compensation
if the skew measurement error occurs	Skew Measurement

Table 3-3 System Configuration Setup Parameters

Field name		Description
Controller		Select <i>B1500A Internal</i> or <i>External PC</i> .
Instrumentations	PGU, DSO, and SMU	Specify the pulse generator (PGU), oscilloscope (DSO), and DC source monitor (SMU) to be used.
Visa Name ^a		VISA interface ID of the GPIB interface. It must be <code>GP1B0</code> .
GPIB Address ^b	PGU, DSO, and SMU	Enter GPIB address of the pulse generator (PGU), oscilloscope (DSO), and DC source monitor (SMU). If Controller= <i>B1500 Internal</i> , SMU field is not active. If DSO= <i>DSO9000A series</i> , DSO field is not active.
Option button		Opens a dialog box. See “LAN Setup for DSO Control Dialog Box” on page 3-10.
CH Assignment	Gate PGU CH	Enter DSO channel number for Gate pulse output.
	Gate Monitor DSO CH	Enter DSO channel number for Gate voltage monitor.
	Drain Monitor DSO CH	Enter DSO channel number for Drain voltage monitor.
	Drain Bias SMU CH	Enter SMU slot number for Drain voltage output.
SMU for Compensation button		Opens a dialog box. See “SMU CH for Compensation Dialog Box” on page 3-11.

- a. To know the Visa Name, use Agilent Connection Expert. See Figure 3-1 or Figure 3-2.
- b. To know the GPIB address of the instruments, use Agilent Connection Expert on the system controller. Or see the manual of each instrument to know how to set the GPIB address.

Starting System Setup

Perform the following procedures. If you use the DSO/MSO9000A series oscilloscope, also perform the procedure described in “If You Use DSO/MSO9000A Series Oscilloscope” on page 3-7.

NOTE

If you use an external computer as the system controller, skip the following procedures and perform the procedures described in “If You Use External Computer” on page 3-8.

1. Connect GPIB cable between the B1500A and the system instruments if it is still not connected.
2. Connect BNC cable between the pulse generator TRIGGER OUT connector and the oscilloscope AUX Trig In connector if it is still not connected.
3. Turn on the system instruments.

**On the Agilent
Connection Expert**

1. If the B1500A displays the Start EasyEXPERT window, close it first.
2. Launch Agilent Connection Expert (see Figure 3-1).
3. Check the GPIB configuration. The System Controller must be set to Yes.
4. Check the VISA interface ID. It must be GPIB0.
5. Close Agilent Connection Expert.

**On the
EasyEXPERT**

1. Launch EasyEXPERT.
2. Click the Start EasyEXPERT button.
3. Open your workspace or create a new workspace.
4. Display the Application Test tab screen.
5. Open the PLSDIV Setup test definition.
6. Set the DcSwitch field to Yes. Do not set No.
7. Save the test setup to your preset group (My Favorite Setup).

Figure 3-1

Agilent Connection Expert

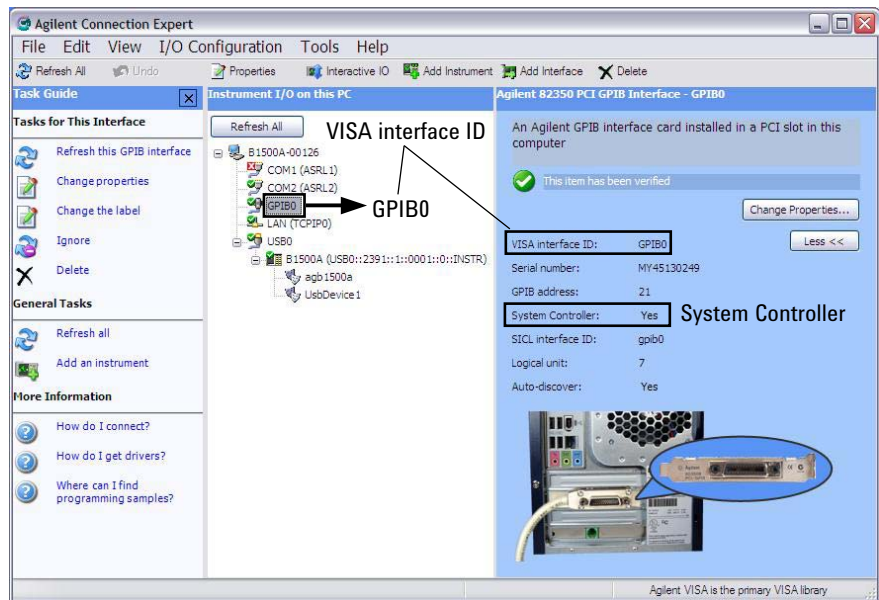

If You Use DSO/MSO9000A Series Oscilloscope

Perform the following procedure to know the IP address of the DSO/MSO9000A series oscilloscope and set it to Agilent Connection Expert. It must be also set to the system setup configuration (see IP Address in Table 3-5). Before performing this procedure, the oscilloscope and B1500A (or computer) must be connected to the LAN of the same subnet mask.

1. On the oscilloscope front panel, check the IP address of the oscilloscope. See the oscilloscope manual for checking the IP address (web address).
2. If the B1500A (or computer) displays the Start EasyEXPERT window, close it first.
3. Launch Agilent Connection Expert.
4. Highlight LAN (TCP/IP0).
5. Add the oscilloscope to the LAN instruments. Then use the IP address checked at the step 1. Also the Device name must be `inst0`.
6. Close Agilent Connection Expert.

If You Use External Computer

Perform the following procedures if you use an external computer as the system controller. If you use the DSO/MSO9000A series oscilloscope, also perform the procedure described in “If You Use DSO/MSO9000A Series Oscilloscope” on page 3-7.

NOTE**If You Use B1500A as DC Source Monitor**

Launch Agilent Connection Expert on the B1500A and set the GPIB configuration as follows.

- GPIB address: appropriate value, non 21 value
- System Controller: *No*

After that reboot the B1500A and leave the Start EasyEXPERT window on the B1500A screen.

1. Connect GPIB cable between the system controller and the system instruments if it is still not connected.
2. Connect BNC cable between the pulse generator TRIGGER OUT connector and the oscilloscope AUX Trig In connector if it is still not connected.
3. Turn on the system instruments.

**On the Agilent
Connection Expert**

1. If the computer displays the Start EasyEXPERT window, close it first.
2. Launch Agilent Connection Expert (see Figure 3-2).
3. Check the VISA interface ID. It must be GPIB0.
4. Close Agilent Connection Expert.

**On the Desktop
EasyEXPERT**

1. Launch Desktop EasyEXPERT.
2. Open the Execution Mode dialog box and set the execution mode as shown in Table 3-4. The dialog box can be opened by selecting the Option > Execution Mode menu on the Start EasyEXPERT window.
3. Click the Start EasyEXPERT button.
4. Open your workspace or create a new workspace.
5. Display the Application Test tab screen.
6. Open the PLSDIV Setup test definition.

7. Set the DcSwitch field to Yes. Do not set No.
8. Save the test setup to your preset group (My Favorite Setup).

Table 3-4 Desktop EasyEXPERT Execution Mode

Mode	Field name	Setting value or description
Offline ^a		Select this mode for using the 4155B, 4155C, 4156B, 4156C, E5260A (or E5262A/E5263A), or E5270B.
	Model	Select 4155B, 4155C, 4156B, or 4156C to be used. Or select B1500A for using the E5260A (or E5262A/E5263A) or E5270B.
Online		Select this mode only for using the B1500A.
	VISA interface ID	VISA interface ID of the computer's GPIB interface. It must be GPIB0.
	GPIB address	Set the GPIB address of the B1500A.

a. Even though the execution mode is *Offline*, the pulsed IV system software can control the DC source monitor.

Figure 3-2

Agilent Connection Expert

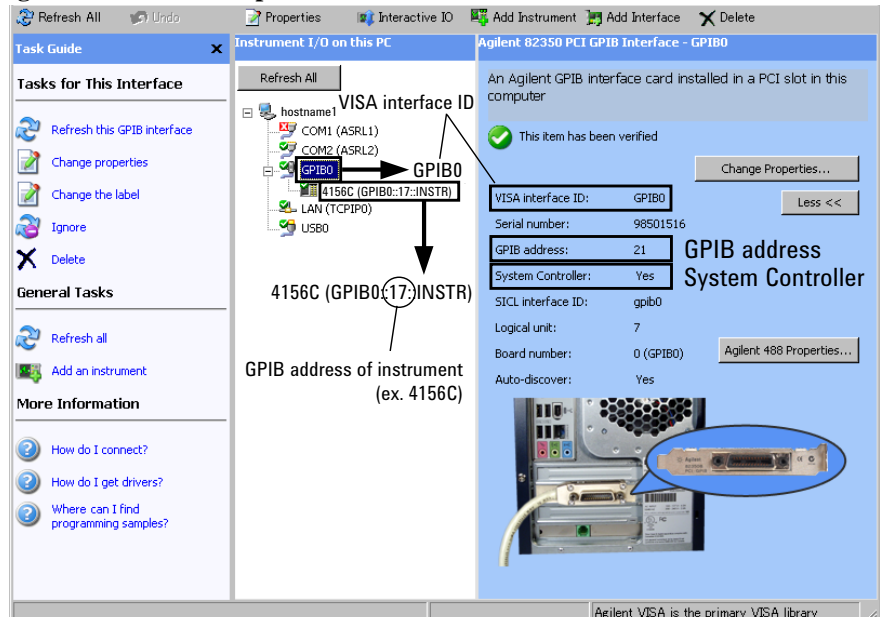

System Configuration

The system configuration must be set after completing the system installation or after changing a channel assignment or after changing the interface address of the system components.

Procedure:

1. Open the PLSDIV Setup test setup from your preset group.
2. Set the Action field to *System Configuration*.
3. Click the Single button at the upper right corner on the EasyEXPERT screen or the Desktop EasyEXPERT screen. The Configuration dialog box is opened.
4. Set and save the system configuration parameters by using the Configuration dialog box. For the setup parameters, see Table 3-3.

LAN Setup for DSO Control Dialog Box

This dialog box is opened by clicking the Option button on the Configuration dialog box, and is used to set the IP address of the DSO/MSO9000A series oscilloscope. Set the IP address properly and click OK.

Table 3-5

LAN Setup for DSO Control Dialog Box

Field Name	Description
IP Address	Enter the IP address of the DSO/MSO9000A series oscilloscope.
Device Name	This field always displays <code>inst0</code> which must be the device name of the oscilloscope for the pulsed IV test system.

SMU CH for Compensation Dialog Box

This dialog box is opened by clicking the SMU for Compensation button on the Configuration dialog box, and is used to specify the SMU used for the Compensation action.

In the default setting, the Compensation action will use the SMU specified by the *Drain Bias SMU CH* field on the Configuration dialog box. For example, if 2 has been set to this field, the Compensation action uses the SMU2 or the SMU installed in the slot number 2.

However, if you specify a SMU on the SMU CH for Compensation dialog box, see Table 3-6, the Compensation action will use the SMU you specify, not the *Drain Bias SMU CH* channel.

Table 3-6

SMU CH for Compensation

Field Name	Description
Force SMU (Slot No.)	Channel number (slot number) of the SMU used for the Kelvin connection Force.
Sense SMU (Slot No.)	Enter the channel number (slot number) of the SMU used for the Kelvin connection Sense.

If you are using the DC source monitor other than the 4155B/C, you do not need to specify the SMU. However, if you want to use the SMU other than the *Drain Bias SMU CH* channel, set the same value to the both fields. The Compensation action will use the specified SMU.

If you are using the 4155B/C, specify two SMUs because the 4155B/C does not have the Sense terminal. The Compensation action will use the specified two SMUs for making the Kelvin connection.

Executing Action

Execute the action as shown below. Before starting the action, confirm that all system components are connected to the system controller and available on the same GPIB bus and on the same LAN for the DSO/MSO9000A series oscilloscope.

1. Open the PLSDIV Setup test setup from your preset group.
2. Set the DcSwitch field to Yes. Do not set No.
3. Click the Extended Setup button and set the SWAddress value.
SWAddress GPIB address of the switch controller. Integer, 1 to 32.
4. Select the action by using the Action field.
 - System Configuration
See “System Configuration” on page 3-10.
 - Compensation
See “Compensation Action” on page 3-13.
 - Skew Measurement
 - Drain Cable Replacement
 - Pgu Compensation
See “Pgu Compensation Action” on page 3-13.
5. Click the Single button at the upper right corner of the EasyEXPERT screen or the Desktop EasyEXPERT screen.
6. Follow the pop-up window and dialog box to complete the action.
You will get navigation for performing the system setup and completing the action.

Compensation Action

Before starting the Compensation action, connect triaxial cables as follows.

1. Connect a triaxial cable to the Force connector of the SMU specified by the *Drain Bias SMU CH* field on the Configuration dialog box or the SMU specified by the *Force SMU (Slot No.)* field on the SMU CH for Compensation dialog box if you set.
2. Connect a triaxial cable to the Sense connector of the SMU specified by the *Drain Bias SMU CH* field on the Configuration dialog box or the SMU specified by the *Sense SMU (Slot No.)* field on the SMU CH for Compensation dialog box if you set.

If you are using the 4155B/C, connect the cable to the Force connector of the SMU specified by the *Sense SMU (Slot No.)* field on the SMU CH for Compensation dialog box.

Pgu Compensation Action

Previously, the Compensation action must be completed successfully.

Before starting the Pgu Compensation action, click the Extended Setup button and set the following parameters. They must be the values you are going to set when performing the pulsed IV measurements actually.

PulseBase	PGU output baseline voltage, -3.0 to 3.0 V
TransTime	Pulse leading/trailing edge transition time, 2 ns to 500 ns
MeasTime	Measurement timing at the pulse top, -1 to 1

For the setup parameters, see “Parameters” on page 5-34.

Performing System Setup and Compensation
Executing Action

4

Performing Measurement

Performing Measurement

This chapter describes the measurement examples by using the pulsed IV test system, and consists of the following sections.

- “Theory of Measurement”
- “Before Measurement”
- “Performing System Reset”
- “Pulse Waveform Measurement”
- “Pulsed Id-Vd Measurement”
- “Pulsed Id-Vg Measurement”
- “DC I-V Measurements”

NOTE

Preparing Measurement Environment

Complete the installation described in Chapter 2, “Installation.”

Complete the system setup and the compensation described in Chapter 3, “Performing System Setup and Compensation.”

Turn on the instruments. And turn on the system controller if it is used.

Launch EasyEXPERT or Desktop EasyEXPERT.

Theory of Measurement

Figure 4-1 shows the pulsed IV measurement circuit diagram.

SMU (source monitor unit) applies DC voltage to the drain terminal through bias-T (bias network). And PGU (pulse generator) applies pulse voltage to the gate terminal through divider. Then the oscilloscope monitors the gate pulse through the divider. Also the oscilloscope monitors the drain pulse through the bias-T by using the another monitor channel.

The 50 Ω terminator must be connected as shown in Figure 4-1 to keep the impedance matching of the instrument's input/output terminals and to avoid the reflection at the gate terminal.

Figure 4-1

Pulsed IV Measurement Circuit Diagram

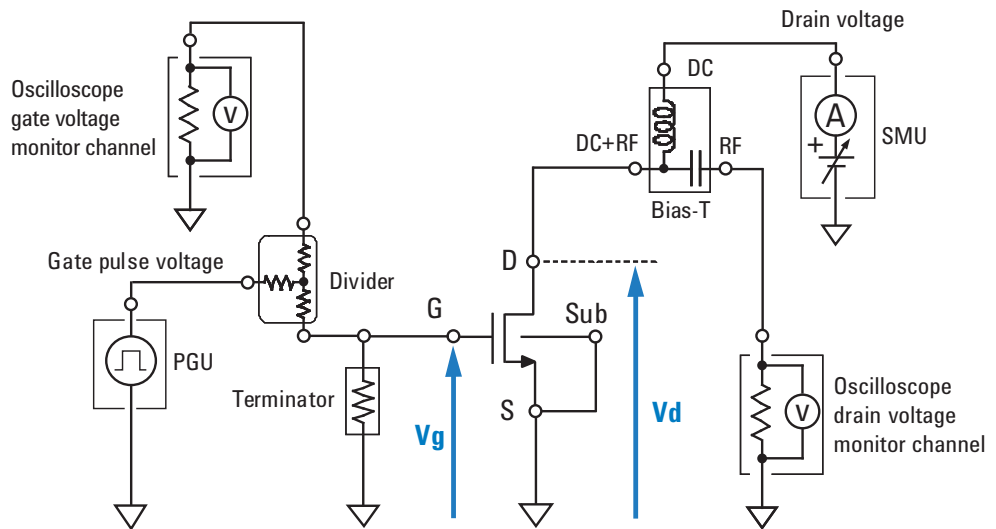

Simplified measurement circuit is shown in Figure 4-2.

$V_{pgu-out}$ is the PGU output voltage (pulse top value). And V_{dSet} is the SMU output voltage. By applying V_{dSet} and $V_{pgu-out}$ to the MOSFET, the oscilloscope's drain voltage monitor channel will capture the voltage drop caused by the shunt resistor Z (impedance of the drain voltage measurement path). And the drain current I_d can be given by the following formula. Where, V_{dInt} is the peak value of the negative pulse.

$$I_d = (V_{dSet} - V_{dInt}) / Z$$

Performing Measurement

Theory of Measurement

The test system repeats this drain current measurement for all of the specified sweep voltage and gets the data to plot on the data display graph.

Figure 4-2

Simplified Measurement Circuit

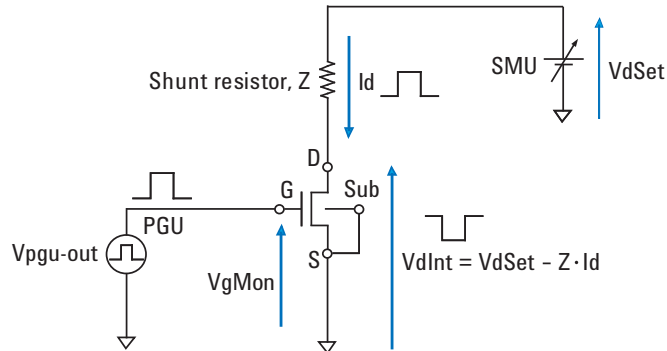

VgMon, VdInt, and Id values will be the value obtained at the specific timing of the pulse top. It is the data extraction timing shown in Figure 5-9.

Terminal Voltage and Source Output Value

In Figure 4-2, VgMon and VdInt are the device terminal voltage. Vpgu-out and VdSet are the source output values. Moreover the values are not same because of the several elements in the measurement path, shunt resistor, residual resistor, and so on. Therefore, it is required to select which value should be the target voltage before performing the measurement. To select it, use the drain voltage automatic adjustment function and the gate voltage automatic adjustment function in the pulsed IV test definitions.

If the drain voltage automatic adjustment function is ON, VdInt will be close to the target voltage Vd. And if the function is OFF, VdSet will be close to Vd.

If the gate voltage automatic adjustment function is ON, VgMon will be close to the target voltage Vg. And if the function is OFF, Vpgu-out will be close to Vg.

The target voltage Vd is calculated from the Test Parameters VdStart, VdStop, and VdStep in the pulsed IV test definition. And Vg is calculated from VgStart, VgStop, and VgStep.

Before Measurement

Confirm or perform the followings before starting measurement.

1. Performing system reset

Perform system reset. See “Performing System Reset” on page 4-6.

2. Deciding device delay time

This is needed to set the DeviceDelay value of the Device Parameters on the pulsed IV test setup screen.

Connect the device under test (MOSFET) to the pulsed IV test system as shown in “RF Probes” on page 2-4, and measure the delay time between the gate monitor pulse and the drain monitor pulse by using the oscilloscope. Then decide the device delay time shown in Figure 4-3.

3. DcSwitch value on Extended Setup dialog box of pulsed IV test setup

Set Yes to use the pulse/dc switch. Do not set No.

4. SWAddress value on Extended Setup dialog box of pulsed IV test setup

Set GPIB address of the switch controller.

Figure 4-3

Device Delay Time

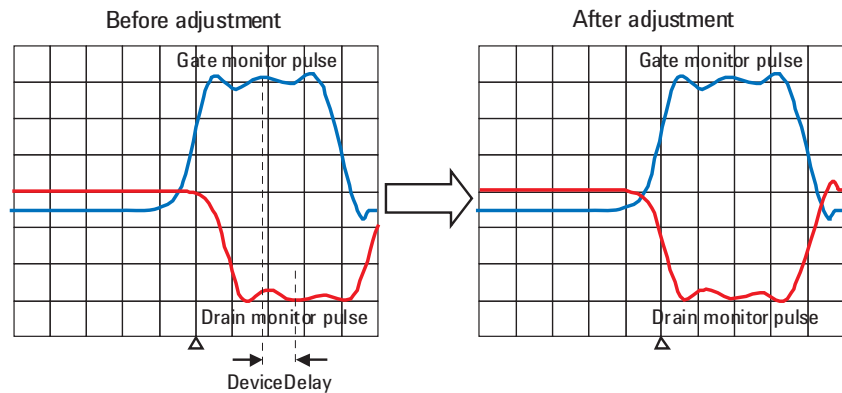

Performing System Reset

This test definition resets the pulsed IV test system. Execute this definition when the test system is in an abnormal condition.

1. Open the PLSDIV Reset test definition on the EasyEXPERT application test environment.
2. Click the Single button at the upper right corner of the EasyEXPERT screen. The system reset is performed.

Figure 4-4

PLSDIV Reset Test Definition

Flag	Setup Name	Date	Count	Device ID	Remarks
	PLSIV Capt Wave	6/20/2006 4:04:41 PM	1		
	PLSIV DC IdVd	6/20/2006 4:03:46 PM	1		
	PLSIV DC IdVg	6/20/2006 4:03:09 PM	1		
	PLSIV Reset	6/20/2006 4:02:39 PM	1		
	PLSIV IdVg	6/20/2006 4:02:24 PM	1		
	PLSIV IdVd	6/20/2006 4:01:44 PM	1		

Pulse Waveform Measurement

Pulse waveform measurement can be performed as follows.

Figure 4-5

PLSDIV Capt Wave Test Definition

Results	Flag	Setup Name	Date	Count	Device ID	Remarks
		PLSIV Capt Wave	6/20/2006 4:04:41 PM	1		
		PLSIV DC IdVd	6/20/2006 4:03:46 PM	1		
		PLSIV DC IdVg	6/20/2006 4:03:09 PM	1		
		PLSIV Reset	6/20/2006 4:02:39 PM	1		
		PLSIV IdVg	6/20/2006 4:02:24 PM	1		
		PLSIV IdVd	6/20/2006 4:01:44 PM	1		

1. Open the PLSDIV Capt Wave test definition on the EasyEXPERT application test environment.
2. Set the measurement condition to the Device Parameters, Test Parameters, and Extended Test Parameters. For the description of the entry fields, see “PLSDIV Capt Wave” on page 5-4.
3. Connect the device under test (MOSFET) as shown in “RF Probes” on page 2-4.
4. Click the Single button at the upper right corner of the EasyEXPERT screen. Pulse waveform measurement is started.

Figure 4-6 is the measurement result example when DrainMonMode=Voltage, and Figure 4-7 is the example when DrainMonMode=Current.

Performing Measurement Pulse Waveform Measurement

Figure 4-6

Voltage Pulse Measurement Example

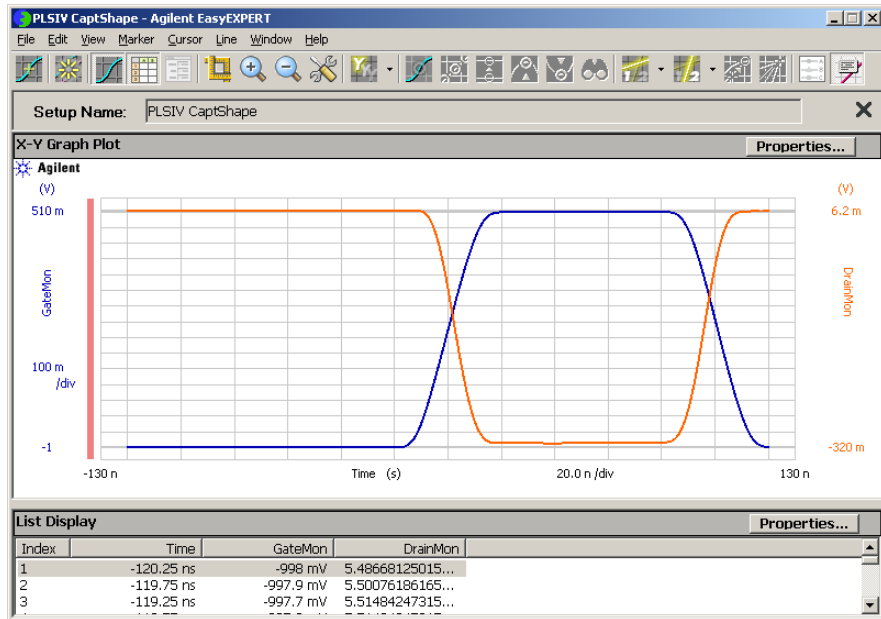
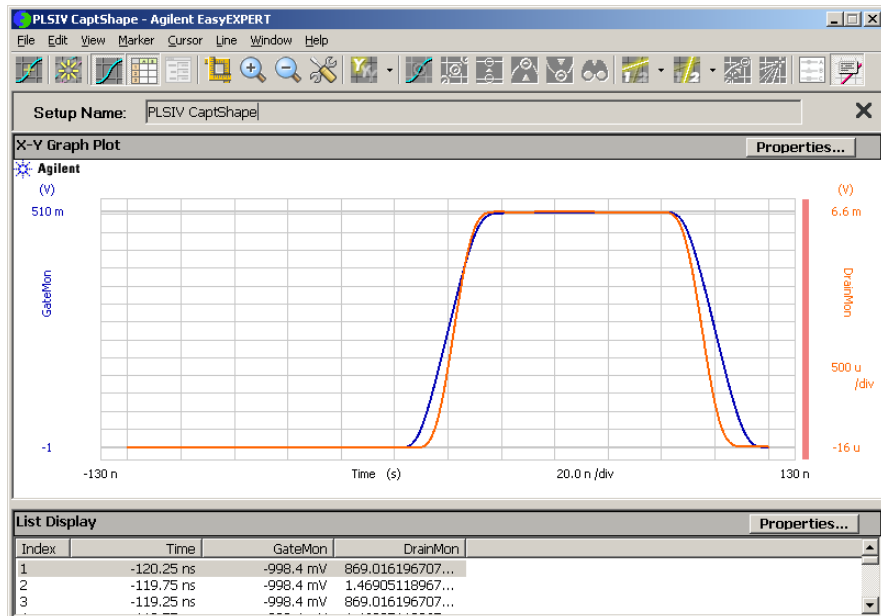

Figure 4-7

Current Pulse Measurement Example



Pulsed Id-Vd Measurement

Pulsed Id-Vd measurement can be performed as follows.

Figure 4-8

PLSDIV IdVd Test Definition

Flag	Setup Name	Date	Count	Device ID	Remarks
	PLSIV Capt Wave	6/20/2006 4:04:41 PM	1		
	PLSIV DC IdVd	6/20/2006 4:03:46 PM	1		
	PLSIV DC IdVg	6/20/2006 4:03:09 PM	1		
	PLSIV Reset	6/20/2006 4:02:39 PM	1		
	PLSIV IdVg	6/20/2006 4:02:24 PM	1		
	PLSIV IdVd	6/20/2006 4:01:44 PM	1		

1. Open the PLSDIV IdVd or PLSDIV IdVd [2] test definition on the EasyEXPERT application test environment.
2. Set the measurement condition to the Device Parameters, Test Parameters, and Extended Test Parameters. For the description of the entry fields, see “PLSDIV IdVd, PLSDIV IdVd [2]” on page 5-19.
3. Connect the device under test (MOSFET) as shown in “RF Probes” on page 2-4.
4. Click the Single button at the upper right corner of the EasyEXPERT screen. Pulsed Id-Vd measurement is started.

Figure 4-9 shows the pulsed Id-Vd measurement result example.

Performing Measurement
Pulsed Id-Vd Measurement

Figure 4-9

Pulsed Id-Vd Measurement Example

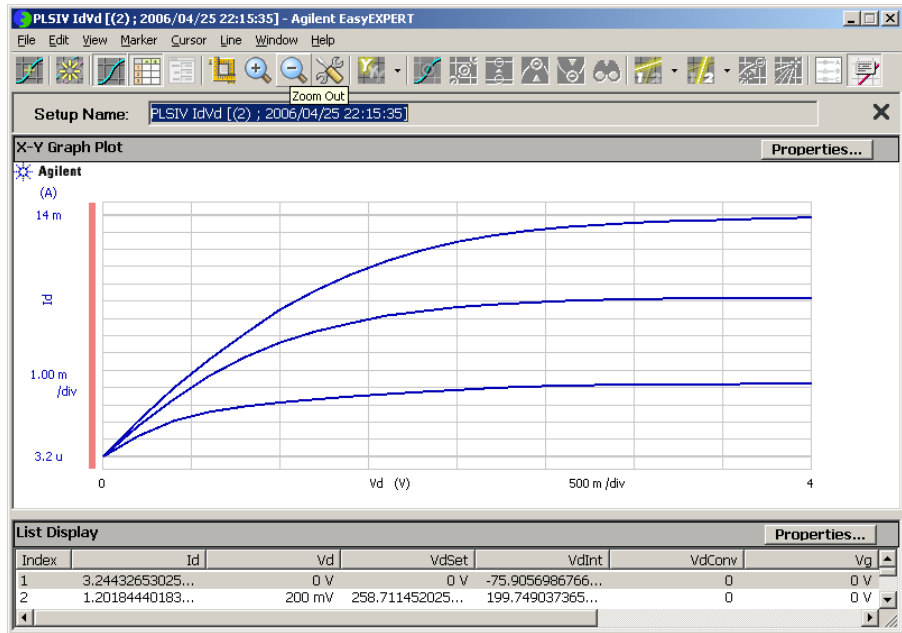

Pulsed Id-Vg Measurement

Pulsed Id-Vg measurement can be performed as follows.

Figure 4-10

PLSDIV IdVg Test Definition

Results	Flag	Setup Name	Date	Count	Device ID	Remarks
		PLSIV Capt Wave	6/20/2006 4:04:41 PM	1		
		PLSIV DC IdVd	6/20/2006 4:03:46 PM	1		
		PLSIV DC IdVg	6/20/2006 4:03:09 PM	1		
		PLSIV Reset	6/20/2006 4:02:39 PM	1		
		PLSIV IdVg	6/20/2006 4:02:24 PM	1		
		PLSIV IdVd	6/20/2006 4:01:44 PM	1		

1. Open the PLSDIV IdVg or PLSDIV IdVg [2] test definition on the EasyEXPERT application test environment.
2. Set the measurement condition to the Device Parameters, Test Parameters, and Extended Test Parameters. For the description of the entry fields, see “PLSDIV IdVg, PLSDIV IdVg [2]” on page 5-23.
3. Connect the device under test (MOSFET) as shown in “RF Probes” on page 2-4.
4. Click the Single button at the upper right corner of the EasyEXPERT screen. Pulsed Id-Vg measurement is started.

Figure 4-11 shows the pulsed Id-Vg measurement result example.

Performing Measurement
Pulsed Id-Vg Measurement

Figure 4-11

Pulsed Id-Vg Measurement Example

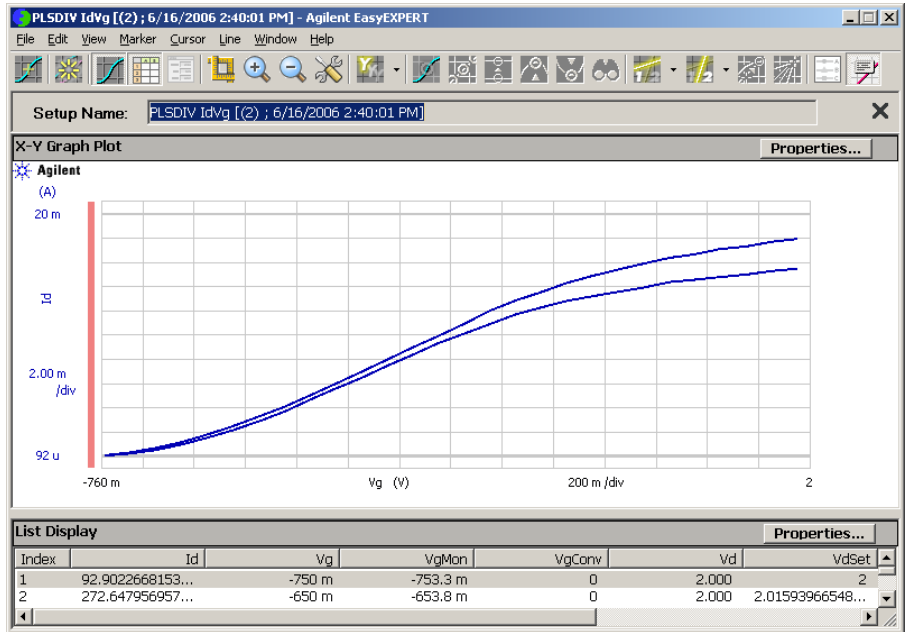

DC I-V Measurements

The PLSDIV system software also provides the test definitions for the DC I-V measurements. The test definitions use SMU and do not use oscilloscope and pulse generator. However, you can perform the measurement as shown in the previous sections.

Table 4-1 lists the DC I-V test definitions and the instruments supported by them.

Table 4-1

DC I-V Test Definitions

Test Definition	Supported Instruments
PLSDIV DC IdVd	B1500A
PLSDIV DC IdVg	4155B/C and 4156B/C
PLSDIV DC IdVd SMU	E5260A (or E5262A/E5263A)
PLSDIV DC IdVg SMU	E5270B
PLSDIV IV SMU	

Performing Measurement
DC I-V Measurements

PLSDIV Test Definitions

This chapter describes the pulsed IV application test library (PLSDIV test definitions) that can be opened and executed in the EasyEXPERT application test environment. The library contains the test definitions shown in Table 5-1.

Each section in this chapter contains detailed descriptions of the test definition. Each entry:

1. Gives one definition
2. Shows the measurement result example
3. Describes the setup parameters
4. Describes the test output parameters
5. Explains any additional information

The test definitions are shown in the alphabetical order.

NOTE

This chapter uses the following conventions.

<system drive>: Drive the pulsed IV system software is installed

<program folder>: Following folder

For Windows 7 64 bit version, <system drive>:\Program Files (x86)

For B1500A, Windows 7 32 bit version, and Windows XP,
<system drive>:\Program Files

NOTE

The PLSDIV test definitions are stored in the following folder.

<program folder>\Agilent\PLSDIV\TestDefinitions

To use the PLSDIV test definitions, import the definitions to your workspace. The test definitions can be imported by the following procedure.

1. Display the Application Test tab screen.
2. Click the Library button, and select Import Test Definition... to open the Test Definition Import dialog box.
3. Import the definitions by using the Test Definition Import dialog box.

Note that the PLSDIV test definitions need the pulsed IV .exe library (Plsdiv commands, PLSDIV TIS) described in Chapter 6, “PLSDIV TIS Commands.”

Table 5-1 Summary of PLSDIV Test Definitions

Test Definition	Description
PLSDIV Setup	This test definition must be executed after installing the pulsed IV test system, changing channel assignment or GPIB address, or replacing oscilloscope, cable, or bias-T.
PLSDIV Reset	Initializes the pulsed IV test system.
PLSDIV Capt Wave	Controls SMU to apply the drain voltage, controls PGU to apply the gate voltage pulse, controls the oscilloscope to monitor the gate voltage pulse waveform and the drain voltage pulse waveform, calculates the drain current pulse waveform if the drain monitor mode is current, and displays the gate voltage pulse waveform and the drain voltage or current pulse waveform.
PLSDIV IdVd, PLSDIV IdVd [2]	Controls SMU (source monitor unit) to apply the drain voltage, controls PGU (pulse generator) to apply the gate voltage pulse, controls the oscilloscope to monitor the gate voltage and the drain voltage, calculates the drain current, and displays the Id-Vd characteristics.
PLSDIV IdVg, PLSDIV IdVg [2]	Controls SMU to apply the drain voltage, controls PGU to apply the gate voltage pulse, controls the oscilloscope to monitor the gate voltage and the drain voltage, calculates the drain current, and displays the Id-Vg characteristics.
PLSDIV DC IdVd, PLSDIV DC IdVd SMU	For the DC Id-Vd measurement. Controls SMUs to apply the drain voltage and the gate voltage, measures the drain current, and displays the Id-Vd characteristics.
PLSDIV DC IdVg, PLSDIV DC IdVg SMU	For the DC Id-Vg measurement. Controls SMUs to apply the drain voltage and the gate voltage and measure the drain current, and displays the Id-Vg characteristics.
PLSDIV IV SMU	For the DC IV sweep measurement. Controls SMUs to apply the primary and secondary sweep voltage, measures current, and displays the I-V characteristics.

For the DC I-V test definitions and the supported instruments, see Table 4-1 on page 4-13.

PLSDIV Capt Wave

This test definition controls SMU (source monitor unit) to apply the drain voltage, controls PGU (pulse generator) to apply the gate voltage pulse, controls the oscilloscope to monitor the gate voltage pulse waveform and the drain voltage pulse waveform, calculates the drain current pulse waveform if the drain monitor mode is current, and displays the gate voltage pulse waveform and the drain voltage or current pulse waveform.

Figure 5-1

Pulse Waveform Measurement Result Example

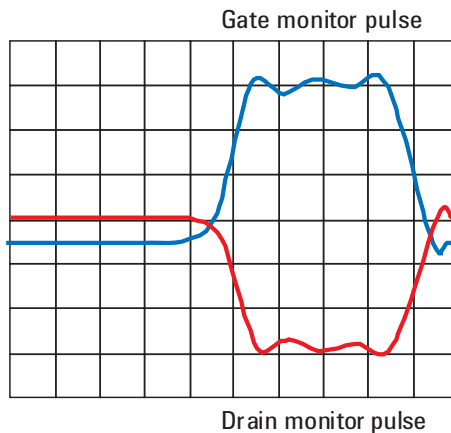

Device Parameters The following parameters are available to set the test condition.

Polarity	Polarity of source output. Nch (applies the specified value) or Pch (applies the negative specified value). See “Parameters” on page 5-34.
Lg	Gate length, in m. ≥ 1 nm, 4 digits or 1 nm resolution.
Wg	Gate width, in m. ≥ 1 nm, 4 digits or 1 nm resolution.
Temp	Temperature, in degree. 4 digits or 0.001 degree resolution.
IdMax	Maximum drain current measurement range, in A. 0 to 80 mA, 4 digits or 1 μ A resolution.
DeviceDelay	Delay time caused by device under test, in s. -1μ s to 1 μ s, 4 digits or 100 ps resolution. See “Parameters” on page 5-34.

Test Parameters

The following parameters are available to set the source output.

PulseWidth	Pulse width of PGU output pulse. 10 ns to 1 μ s, 4 digits or 1 ns resolution. See “Parameters” on page 5-34.
Vg	Voltage applied to the gate terminal. PGU output. -4.5 V to 4.5 V, 4 digits or 10 mV resolution.
PulseBase	PGU output baseline voltage. -3.0 to 3.0 V, 4 digits or 10 mV resolution. See “Parameters” on page 5-34. Pulse amplitude must be > 55 mV and < 4.5 V. To use the gate voltage automatic adjustment function, set the pulse amplitude to < 4.0 V.
Vd	Voltage applied to the drain terminal. SMU output. -10 V to 10 V, 5 digits or 1 mV resolution.

Extended Test Parameters

The following parameters are available to set the test condition. For more details, see “Parameters” on page 5-34.

TransTime	<p>Pulse leading/trailing edge transition time, in s. 2 ns to 500 ns, 3 digits or 1 ns resolution.</p> <p>For the 81101A, minimum value is 5 ns.</p> <p>For the 81150A, minimum value is 2.5 ns when the following conditions are satisfied, or 7.5 ns.</p> <ul style="list-style-type: none"> • Pulse amplitude is 2.5 V or less. • Both pulse base and top are within ± 2.5 V.
MeasTime	Measurement timing at the pulse top. 0 to 1, 3 digits or 0.01 resolution.
SmplNum	Oscilloscope sampling number. 16 to 262144, 6 digits or 1 step.
SmthNum	Oscilloscope smoothing number. 3 to 4001, 4 digits or 1 step.
SmthStat	Status of the oscilloscope smoothing. Enable or Disable.
AvgNum	Oscilloscope averaging number. 1 to 4095, 4 digits or 1 step.
VdAdjust	Status of the drain voltage automatic adjustment. Enable or Disable.
VgAdjust	Status of the gate voltage automatic adjustment. Enable or Disable.
ConnectChk	Status of the connection check at initialization. Enable or Disable.

PLSDIV Test Definitions

PLSDIV Capt Wave

GateZero	Status of the gate monitor channel zero measurement at initialization. Enable or Disable.
RangingMode	Measurement ranging mode. Auto or Fixed.
DcSwitch	Pulse/dc switch units. Yes (exists, pulsed IV measurement connection will be automatically made) or No (none).
SWAddress	GPIB address of the switch controller. Integer, 1 to 32.
DrainMonMode	Drain monitor mode. Current or Voltage.

Test Output

The following output parameters are displayed after the test.

Time	Oscilloscope time data, in s.
GateMon	Oscilloscope gate voltage waveform data, in V.
DrainMon	Oscilloscope drain current waveform, in A, if DrainMonMode=Current. Drain voltage waveform data, in V, if DrainMonMode=Voltage.

The drain voltage waveform data will be the data after compensation.

The drain current waveform data will be the data given by converting the drain voltage waveform data.

PLSDIV DC IdVd

This test definition controls SMUs to apply the drain voltage and the gate voltage, measures the drain current, and displays the Id-Vd characteristics.

Device Parameters The following parameters are available to set the test condition.

Polarity	Polarity of source output. Nch (applies the specified value) or Pch (applies the negative specified value).
Lg	Gate length, in m. ≥ 1 nm, 4 digits or 1 nm resolution.
Wg	Gate width, in m. ≥ 1 nm, 4 digits or 1 nm resolution.
Temp	Temperature, in degree. 4 digits or 0.001 degree resolution.
IdMax	Maximum drain current measurement range, in A. 0 to 80 mA, 4 digits or 1 μ A resolution.

Test Parameters The following parameters are available to set the source output.

CableR	Residual resistance of the gate measurement path from SMU to terminator. ≥ 0 Ω , 4 digits or 1 m Ω resolution.
TermR	Resistance of terminator. ≥ 1 m Ω , 4 digits or 1 m Ω resolution. TermR=No applies 1E+30 Ω .
Gate	SMU connected to the gate terminal.
VgStart	Secondary sweep start voltage for the gate terminal. -10 to 10 V, 4 digits or 10 mV resolution.
VgStop	Secondary sweep stop voltage for the gate terminal. -10 to 10 V, 4 digits or 10 mV resolution.
VgStep	Secondary sweep step voltage for the gate terminal. -10 to 10 V, 5 digits or 1 mV resolution.
Drain	SMU connected to the drain terminal.
VdStart	Primary sweep start voltage for the drain terminal. -10 to 10 V, 4 digits or 10 mV resolution.
VdStop	Primary sweep stop voltage for the drain terminal. -10 to 10 V, 4 digits or 10 mV resolution.
VdStep	Primary sweep step voltage for the drain terminal. -10 to 10 V, 5 digits or 1 mV resolution.

PLSDIV Test Definitions

PLSDIV DC IdVd

- VdStart, VdStop, VdStep

The parameters set the primary sweep source used to apply the drain voltage. The number of sweep points is given by the following formula. Then ignore the numbers after the decimal point. If VdStep=0, the measurement voltage is VdStart only.

$$\text{Number of sweep points} = (\text{VdStop} - \text{VdStart}) / \text{VdStep} + 1$$

- VgStart, VgStop, VgStep

The parameters set the secondary sweep source used to apply the gate voltage. The number of sweep points is given by the following formula. Then ignore the numbers after the decimal point. If VgStep=0, the measurement voltage is VgStart only.

$$\text{Number of sweep points} = (\text{VgStop} - \text{VgStart}) / \text{VgStep} + 1$$

- Gate voltage

To apply the specified voltage (Vg) to the gate terminal, the SMU output voltage (VgSet) will be set to the following value.

$$\text{VgSet} = \text{Vg} * (\text{TermR} + \text{CableR}) / \text{TermR}$$

Extended Test Parameters

The following parameters are available to set the test condition.

IgLimit	Gate current compliance, in A. 1 nA to 100 mA, 3 digits or 1 nA resolution. Set the value that covers current to the terminator. For example, the current is 100 mA for TermR=50 Ω with Vg=5 V.
IntegTime	Integration time. SHORT, MEDIUM, or LONG.
HoldTime	Hold time, in s. 0 to 655.35. 5 digits or 10 ms resolution.
DelayTime	Delay time, in s. 0 to 655.35. 5 digits or 100 μs resolution.
DcSwitch	Pulse/dc switch units. Yes (exists, DC IV measurement connection will be automatically made) or No (none).
SWAddress	GPIO address of the switch controller. Integer, 1 to 32.

Test Output

The following output parameters are displayed after the test.

VgSet	Gate voltage, in V. SMU output value.
Vg	Gate voltage, in V. Target value at the gate terminal.
Vdrain	Drain voltage, in V. SMU output value.
Id	Drain current, in A.
IdPerWg	Drain current per unit gate width, in A/μm. $IdPerWg = Id / Wg$

PLSDIV DC IdVd SMU

This test definition controls SMUs to apply the drain voltage and the gate voltage, measures the drain current, and displays the Id-Vd characteristics.

Device Parameters The following parameters are available to set the test condition.

Polarity	Polarity of source output. Nch (applies the specified value) or Pch (applies the negative specified value).
Lg	Gate length, in m. ≥ 1 nm, 4 digits or 1 nm resolution.
Wg	Gate width, in m. ≥ 1 nm, 4 digits or 1 nm resolution.
Temp	Temperature, in degree. 4 digits or 0.001 degree resolution.
IdMax	Maximum drain current measurement range, in A. 0 to 80 mA, 4 digits or 1 μ A resolution.

Test Parameters The following parameters are available to set the source output.

CableR	Residual resistance of the gate measurement path from SMU to terminator. ≥ 0 Ω , 4 digits or 1 m Ω resolution.
TermR	Resistance of terminator. ≥ 1 m Ω , 4 digits or 1 m Ω resolution. TermR=No applies 1E+30 Ω .
Gate	Channel number of the SMU connected to the gate terminal. Slot1 to Slot8. Maximum channel number depends on the configuration of DC source monitor.
VgStart	Secondary sweep start voltage for the gate terminal. -10 to 10 V, 4 digits or 10 mV resolution.
VgStop	Secondary sweep stop voltage for the gate terminal. -10 to 10 V, 4 digits or 10 mV resolution.
VgStep	Secondary sweep step voltage for the gate terminal. -10 to 10 V, 5 digits or 1 mV resolution.
Drain	Channel number of the SMU connected to the drain terminal. Slot1 to Slot8. Maximum channel number depends on the configuration of DC source monitor.
VdStart	Primary sweep start voltage for the drain terminal. -10 to 10 V, 4 digits or 10 mV resolution.

- VdStop** Primary sweep stop voltage for the drain terminal. –10 to 10 V, 4 digits or 10 mV resolution.
- VdStep** Primary sweep step voltage for the drain terminal. –10 to 10 V, 5 digits or 1 mV resolution.

- VdStart, VdStop, VdStep

The parameters set the primary sweep source used to apply the drain voltage. The number of sweep points is given by the following formula. Then ignore the numbers after the decimal point. If VdStep=0, the measurement voltage is VdStart only.

$$\text{Number of sweep points} = (\text{VdStop} - \text{VdStart}) / \text{VdStep} + 1$$

- VgStart, VgStop, VgStep

The parameters set the secondary sweep source used to apply the gate voltage. The number of sweep points is given by the following formula. Then ignore the numbers after the decimal point. If VgStep=0, the measurement voltage is VgStart only.

$$\text{Number of sweep points} = (\text{VgStop} - \text{VgStart}) / \text{VgStep} + 1$$

- Gate voltage

To apply the specified voltage (Vg) to the gate terminal, the SMU output voltage (VgSet) will be set to the following value.

$$\text{VgSet} = \text{Vg} * (\text{TermR} + \text{CableR}) / \text{TermR}$$

Extended Test Parameters

The following parameters are available to set the test condition.

- IgLimit** Gate current compliance, in A. 1 nA to 100 mA, 3 digits or 1 nA resolution. Set the value that covers current to the terminator. For example, the current is 100 mA for TermR=50 Ω with Vg=5 V.
- Ranging** Current measurement ranging mode. Auto, LimitedAuto, or Fixed.
- Irange** Current measurement range. 10 pA to 100 mA. 6 digits or 10 pA resolution. Available measurement range depends on the type of SMU.
- ADCType** Only for the E5260/E5270 series. Type of A/D converter. HighSpeed or HighResolution
- IntegMode** Only for the E5260/E5270 series. Integration mode. Auto, Manual, or PLC.

PLSDIV Test Definitions

PLSDIV DC IdVd SMU

IntegNum	<p>For E5260/E5270, this parameter is the coefficient used to define the integration time or the number of averaging samples for the current measurement. Integer. See Table 5-2.</p> <p>For 4155/4156, this parameter is the number of averaging samples if this value is positive, or the NPLC value if this value is negative. Integer, -1023 to 1023. IntegNum=-1023 to -101 give the same result as IntegNum=-100. The NPLC means the number of power line cycles for the current measurement.</p>
HoldTime	Hold time, in s. 0 to 655.35. 5 digits or 10 ms resolution.
DelayTime	Delay time, in s. 0 to 655.35. 5 digits or 100 μ s resolution.
InstType	Type of DC source monitor. E526x, E527x, or FLEX415x. E526x: for Agilent E5260A E527x: for Agilent E5270B FLEX415x: for Agilent 4155/4156
InstAddress	GPIB address of the DC source monitor. Integer, 1 to 32.
DcSwitch	Pulse/dc switch units. Yes (exists, DC IV measurement connection will be automatically made) or No (none).
SWAddress	GPIB address of the switch controller. Integer, 1 to 32.

Test Output

The following output parameters are displayed after the test.

VgSet	Gate voltage, in V. SMU output value.
Vg	Gate voltage, in V. Target value at the gate terminal.
Vdrain	Drain voltage, in V. SMU output value.
Id	Drain current, in A.
IdPerWg	Drain current per unit gate width, in A/ μ m. $IdPerWg = Id / Wg$

PLSDIV DC IdVg

This test definition controls SMUs to apply the drain voltage and the gate voltage, measures the drain current, and displays the Id-Vg characteristics.

Device Parameters The following parameters are available to set the test condition.

Polarity	Polarity of source output. Nch (applies the specified value) or Pch (applies the negative specified value).
Lg	Gate length, in m. ≥ 1 nm, 4 digits or 1 nm resolution.
Wg	Gate width, in m. ≥ 1 nm, 4 digits or 1 nm resolution.
Temp	Temperature, in degree. 4 digits or 0.001 degree resolution.
IdMax	Maximum drain current measurement range, in A. 0 to 80 mA, 4 digits or 1 μ A resolution.

Test Parameters The following parameters are available to set the source output.

CableR	Residual resistance of the gate measurement path from SMU to terminator. ≥ 0 Ω , 4 digits or 1 m Ω resolution.
TermR	Resistance of terminator. ≥ 1 m Ω , 4 digits or 1 m Ω resolution. TermR=No applies 1E+30 Ω .
Gate	SMU connected to the gate terminal.
VgStart	Primary sweep start voltage for the gate terminal. -10 to 10 V, 4 digits or 10 mV resolution.
VgStop	Primary sweep stop voltage for the gate terminal. -10 to 10 V, 4 digits or 10 mV resolution.
VgStep	Primary sweep step voltage for the gate terminal. -10 to 10 V, 5 digits or 1 mV resolution.
Drain	SMU connected to the drain terminal.
VdStart	Secondary sweep start voltage for the drain terminal. -10 to 10 V, 4 digits or 10 mV resolution.
VdStop	Secondary sweep stop voltage for the drain terminal. -10 to 10 V, 4 digits or 10 mV resolution.
VdStep	Secondary sweep step voltage for the drain terminal. -10 to 10 V, 5 digits or 1 mV resolution.

PLSDIV Test Definitions

PLSDIV DC IdVg

- VgStart, VgStop, VgStep

The parameters set the primary sweep source used to apply the gate voltage. The number of sweep points is given by the following formula. Then ignore the numbers after the decimal point. If VgStep=0, the measurement voltage is VgStart only.

$$\text{Number of sweep points} = (\text{VgStop} - \text{VgStart}) / \text{VgStep} + 1$$

- VdStart, VdStop, VdStep

The parameters set the secondary sweep source used to apply the drain voltage. The number of sweep points is given by the following formula. Then ignore the numbers after the decimal point. If VdStep=0, the measurement voltage is VdStart only.

$$\text{Number of sweep points} = (\text{VdStop} - \text{VdStart}) / \text{VdStep} + 1$$

- Gate voltage

To apply the specified voltage (Vg) to the gate terminal, the SMU output voltage (VgSet) will be set to the following value.

$$\text{VgSet} = \text{Vg} * (\text{TermR} + \text{CableR}) / \text{TermR}$$

Extended Test Parameters

The following parameters are available to set the test condition.

IgLimit	Gate current compliance, in A. 1 nA to 100 mA, 3 digits or 1 nA resolution. Set the value that covers current to the terminator. For example, the current is 100 mA for TermR=50 Ω with Vg=5 V.
IntegTime	Integration time. SHORT, MEDIUM, or LONG.
HoldTime	Hold time, in s. 0 to 655.35. 5 digits or 10 ms resolution.
DelayTime	Delay time, in s. 0 to 655.35. 5 digits or 100 μs resolution.
DcSwitch	Pulse/dc switch units. Yes (exists, DC IV measurement connection will be automatically made) or No (none).
SWAddress	GPIB address of the switch controller. Integer, 1 to 32.

Test Output

The following output parameters are displayed after the test.

VgSet	Gate voltage, in V. SMU output value.
Vg	Target gate voltage, in V.
Vdrain	Drain voltage, in V. SMU output value.
Id	Drain current, in A.
IdPerWg	Drain current per unit gate width, in A/μm. $IdPerWg = Id / Wg$

PLSDIV DC IdVg SMU

This test definition controls SMUs to apply the drain voltage and the gate voltage, measures the drain current, and displays the Id-Vg characteristics.

Device Parameters The following parameters are available to set the test condition.

Polarity	Polarity of source output. Nch (applies the specified value) or Pch (applies the negative specified value).
Lg	Gate length, in m. ≥ 1 nm, 4 digits or 1 nm resolution.
Wg	Gate width, in m. ≥ 1 nm, 4 digits or 1 nm resolution.
Temp	Temperature, in degree. 4 digits or 0.001 degree resolution.
IdMax	Maximum drain current measurement range, in A. 0 to 80 mA, 4 digits or 1 μ A resolution.

Test Parameters The following parameters are available to set the source output.

CableR	Residual resistance of the gate measurement path from SMU to terminator. ≥ 0 Ω , 4 digits or 1 m Ω resolution.
TermR	Resistance of terminator. ≥ 1 m Ω , 4 digits or 1 m Ω resolution. TermR=No applies 1E+30 Ω .
Gate	Channel number of the SMU connected to the gate terminal. Slot1 to Slot8. Maximum channel number depends on the configuration of DC source monitor.
VgStart	Primary sweep start voltage for the gate terminal. -10 to 10 V, 4 digits or 10 mV resolution.
VgStop	Primary sweep stop voltage for the gate terminal. -10 to 10 V, 4 digits or 10 mV resolution.
VgStep	Primary sweep step voltage for the gate terminal. -10 to 10 V, 5 digits or 1 mV resolution.
Drain	Channel number of the SMU connected to the drain terminal. Slot1 to Slot8. Maximum channel number depends on the configuration of DC source monitor.
VdStart	Secondary sweep start voltage for the drain terminal. -10 to 10 V, 4 digits or 10 mV resolution.

- VdStop** Secondary sweep stop voltage for the drain terminal. -10 to 10 V, 4 digits or 10 mV resolution.
- VdStep** Secondary sweep step voltage for the drain terminal. -10 to 10 V, 5 digits or 1 mV resolution.

- **VgStart, VgStop, VgStep**

The parameters set the primary sweep source used to apply the gate voltage. The number of sweep points is given by the following formula. Then ignore the numbers after the decimal point. If VgStep=0, the measurement voltage is VgStart only.

$$\text{Number of sweep points} = (\text{VgStop} - \text{VgStart}) / \text{VgStep} + 1$$

- **VdStart, VdStop, VdStep**

The parameters set the secondary sweep source used to apply the drain voltage. The number of sweep points is given by the following formula. Then ignore the numbers after the decimal point. If VdStep=0, the measurement voltage is VdStart only.

$$\text{Number of sweep points} = (\text{VdStop} - \text{VdStart}) / \text{VdStep} + 1$$

- **Gate voltage**

To apply the specified voltage (Vg) to the gate terminal, the SMU output voltage (VgSet) will be set to the following value.

$$\text{VgSet} = \text{Vg} * (\text{TermR} + \text{CableR}) / \text{TermR}$$

Extended Test Parameters

The following parameters are available to set the test condition.

- IgLimit** Gate current compliance, in A. 1 nA to 100 mA, 3 digits or 1 nA resolution. Set the value that covers current to the terminator. For example, the current is 100 mA for TermR=50 Ω with Vg=5 V.
- Ranging** Current measurement ranging mode. Auto, LimitedAuto, or Fixed.
- Irange** Current measurement range. 10 pA to 100 mA. 6 digits or 10 pA resolution. Available measurement range depends on the type of SMU.
- ADCType** Only for the E5260/E5270 series. Type of A/D converter. HighSpeed or HighResolution
- IntegMode** Only for the E5260/E5270 series. Integration mode. Auto, Manual, or PLC.

PLSDIV Test Definitions

PLSDIV DC IdVg SMU

IntegNum	<p>For E5260/E5270, this parameter is the coefficient used to define the integration time or the number of averaging samples for the current measurement. Integer. See Table 5-2.</p> <p>For 4155/4156, this parameter is the number of averaging samples if this value is positive, or the NPLC value if this value is negative. Integer, -1023 to 1023. IntegNum=-1023 to -101 give the same result as IntegNum=-100. The NPLC means the number of power line cycles for the current measurement.</p>
HoldTime	Hold time, in s. 0 to 655.35. 5 digits or 10 ms resolution.
DelayTime	Delay time, in s. 0 to 655.35. 5 digits or 100 μ s resolution.
InstType	Type of DC source monitor. E526x, E527x, or FLEX415x. E526x: for Agilent E5260A E527x: for Agilent E5270B FLEX415x: for Agilent 4155/4156
InstAddress	GPIB address of the DC source monitor. Integer, 1 to 32.
DcSwitch	Pulse/dc switch units. Yes (exists, DC IV measurement connection will be automatically made) or No (none).
SWAddress	GPIB address of the switch controller. Integer, 1 to 32.

Test Output

The following output parameters are displayed after the test.

VgSet	Gate voltage, in V. SMU output value.
Vg	Target gate voltage, in V.
Vdrain	Drain voltage, in V. SMU output value.
Id	Drain current, in A.
IdPerWg	Drain current per unit gate width, in A/ μ m. $IdPerWg = Id / Wg$

PLSDIV IdVd, PLSDIV IdVd [2]

This test definition controls SMU (source monitor unit) to apply the drain voltage, controls PGU (pulse generator) to apply the gate voltage pulse, controls the oscilloscope to monitor the gate voltage and the drain voltage, calculates the drain current, and displays the Id-Vd characteristics.

Difference between these test definitions is data display. PLSDIV IdVd updates the graph every sweep point. And PLSDIV IdVd [2] updates the graph after the pulsed IV measurement. So PLSDIV IdVd [2] test speed is faster than PLSDIV IdVd.

Figure 5-2

Pulsed IV Id-Vd Measurement Result Example

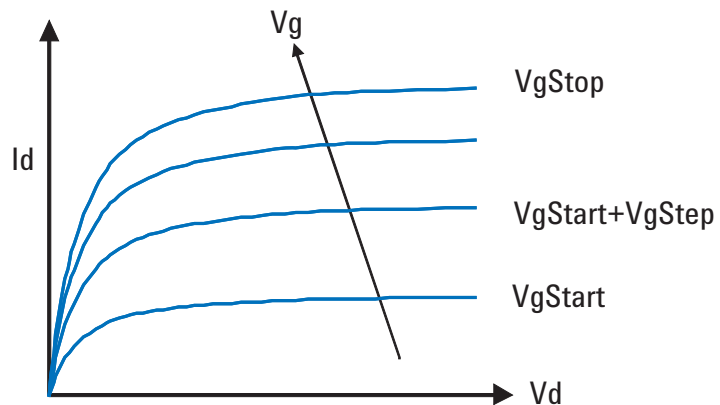

Device Parameters The following parameters are available to set the test condition.

Polarity	Polarity of source output. Nch (applies the specified value) or Pch (applies the negative specified value). See “Parameters” on page 5-34.
Lg	Gate length, in m. ≥ 1 nm, 4 digits or 1 nm resolution.
Wg	Gate width, in m. ≥ 1 nm, 4 digits or 1 nm resolution.
Temp	Temperature, in degree. 4 digits or 0.001 degree resolution.
IdMax	Maximum drain current measurement range, in A. 0 to 80 mA, 4 digits or 1 μ A resolution.
DeviceDelay	Delay time caused by device under test, in s. -1 μ s to 1 μ s, 4 digits or 100 ps resolution. See “Parameters” on page 5-34.

PLSDIV Test Definitions

PLSDIV IdVd, PLSDIV IdVd [2]

Test Parameters

The following parameters are available to set the source output.

PulseWidth	Pulse width of PGU output pulse. 10 ns to 1 μ s, 4 digits or 1 ns resolution. See “Parameters” on page 5-34.
VgStart	Secondary sweep start voltage for the gate terminal. PGU output. -4.5 V to 4.5 V, 4 digits or 10 mV resolution.
VgStop	Secondary sweep stop voltage for the gate terminal. PGU output. -4.5 V to 4.5 V, 4 digits or 10 mV resolution.
VgStep	Secondary sweep step voltage for the gate terminal. PGU output. 10 mV to 4.5 V, 4 digits or 10 mV resolution.
PulseBase	PGU output baseline voltage. -3.0 to 3.0 V, 4 digits or 10 mV resolution. See “Parameters” on page 5-34.
VdStart	Primary sweep start voltage for the drain terminal. SMU output. -10 V to 10 V, 5 digits or 1 mV resolution.
VdStop	Primary sweep stop voltage for the drain terminal. SMU output. -10 V to 10 V, 5 digits or 1 mV resolution.
VdStep	Primary sweep step voltage for the drain terminal. SMU output. -10 V to 10 V, 5 digits or 1 mV resolution.

- VdStart, VdStop, VdStep

The parameters set the primary sweep source used to apply the drain voltage. The number of sweep points is given by the following formula. Then ignore the numbers after the decimal point. If VdStep=0, the measurement voltage is VdStart only.

$$\text{Number of sweep points} = (\text{VdStop} - \text{VdStart}) / \text{VdStep} + 1$$

- VgStart, VgStop, VgStep

The parameters set the secondary sweep source used to apply the gate voltage. The number of sweep points is given by the following formula. Then ignore the numbers after the decimal point. If VgStep=0, the measurement voltage is VgStart only.

$$\text{Number of sweep points} = (\text{VgStop} - \text{VgStart}) / \text{VgStep} + 1$$

Pulse amplitude must be > 55 mV and < 4.5 V. So $|\text{VgStart} - \text{PulseBase}|$ and $|\text{VgStop} - \text{PulseBase}|$ must be > 55 mV and < 4.5 V.

To use the gate voltage automatic adjustment function, set the pulse amplitude to < 4.0 V.

Extended Test Parameters

The following parameters are available to set the test condition. For more details, see “Parameters” on page 5-34.

TransTime	Pulse leading/trailing edge transition time, in s. 2 ns to 500 ns, 3 digits or 1 ns resolution. For the 81101A, minimum value is 5 ns. For the 81150A, minimum value is 2.5 ns when the following conditions are satisfied, or 7.5 ns. <ul style="list-style-type: none"> • Pulse amplitude is 2.5 V or less. • Both pulse base and top are within ± 2.5 V.
MeasTime	Measurement timing at the pulse top. 0 to 1, 3 digits or 0.01 resolution.
SmplNum	Oscilloscope sampling number. 16 to 262144, 6 digits or 1 step.
SmthNum	Oscilloscope smoothing number. 3 to 4001, 4 digits or 1 step.
SmthStat	Status of the oscilloscope smoothing. Enable or Disable.
AvgNum	Oscilloscope averaging number. 1 to 4095, 4 digits or 1 step.
VdAdjust	Status of the drain voltage automatic adjustment. Enable or Disable.
VgAdjust	Status of the gate voltage automatic adjustment. Enable or Disable.
RangingMode	Measurement ranging mode. Auto or Fixed.
ConnectChk	Status of the connection check at initialization. Enable or Disable.
GateZero	Status of the gate monitor channel zero measurement at initialization. Enable or Disable.
DcSwitch	Pulse/dc switch units. Yes (exists, pulsed IV measurement connection will be automatically made) or No (none).
SWAddress	GPIB address of the switch controller. Integer, 1 to 32.

PLSDIV Test Definitions
 PLSDIV IdVd, PLSDIV IdVd [2]

Test Output

The following output parameters are displayed after the test.

Idrain	Drain current Id, in A.
Vdrain	Target drain voltage Vd, in V.
VdSet	Drain voltage, in V. SMU output value.
VdInt	Drain voltage, in V. Oscilloscope monitor value.
VdConv	Convergence result of the drain voltage automatic adjustment.
Vgate	Target gate voltage Vg, in V.
VgMon	Gate voltage, in V. Oscilloscope monitor value.
VgConv	Convergence result of the gate voltage automatic adjustment.
IdPerWg	Drain current per unit gate width, in A/μm. $\text{IdPerWg} = \text{Id} / \text{Wg}$

VgMon, VdInt, and Id values will be the value obtained at the data extraction timing on the pulse top. See Figure 5-9.

VdConv and VgConv returns 0 (convergence condition is satisfied) or -1 (not satisfied). If the automatic adjustment is OFF, 0 is returned.

If the drain voltage automatic adjustment function is ON, VdInt will be close to Vd. And if the function is OFF, VdSet will be close to Vd.

If the gate voltage automatic adjustment function is ON, VgMon will be close to Vg. And if the function is OFF, Vpgu-out will be close to Vg.

Figure 5-3

Test Output Parameters

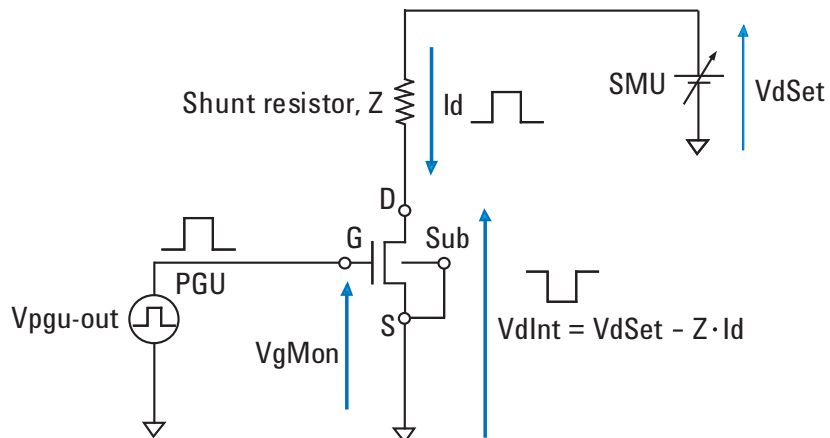

PLSDIV IdVg, PLSDIV IdVg [2]

This test definition controls SMU (source monitor unit) to apply the drain voltage, controls PGU (pulse generator) to apply the gate voltage pulse, controls the oscilloscope to monitor the gate voltage and the drain voltage, calculates the drain current, and displays the Id-Vg characteristics.

Difference between these test definitions is data display. PLSDIV IdVg updates the graph every sweep point. And PLSDIV IdVg [2] updates the graph after the pulsed IV measurement. So PLSDIV IdVg [2] test speed is faster than PLSDIV IdVg.

Figure 5-4 Pulsed IV Id-Vg Measurement Result Example

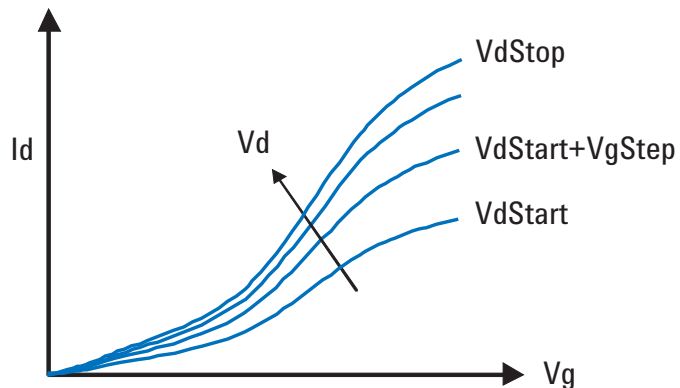

Device Parameters The following parameters are available to set the test condition.

Polarity	Polarity of source output. Nch (applies the specified value) or Pch (applies the negative specified value). See “Parameters” on page 5-34.
Lg	Gate length, in m. ≥ 1 nm, 4 digits or 1 nm resolution.
Wg	Gate width, in m. ≥ 1 nm, 4 digits or 1 nm resolution.
Temp	Temperature, in degree. 4 digits or 0.001 degree resolution.
IdMax	Maximum drain current measurement range, in A. 0 to 80 mA, 4 digits or 1 μ A resolution.
DeviceDelay	Delay time caused by device under test, in s. -1 μ s to 1 μ s, 4 digits or 100 ps resolution. See “Parameters” on page 5-34.

PLSDIV Test Definitions
PLSDIV IdVg, PLSDIV IdVg [2]

Test Parameters

The following parameters are available to set the source output.

PulseWidth	Pulse width of PGU output pulse. 10 ns to 1 μ s, 4 digits or 1 ns resolution. See “Parameters” on page 5-34.
VgStart	Primary sweep start voltage for the gate terminal. PGU output. -4.5 V to 4.5 V, 4 digits or 10 mV resolution.
VgStop	Primary sweep stop voltage for the gate terminal. PGU output. -4.5 V to 4.5 V, 4 digits or 10 mV resolution.
VgStep	Primary sweep step voltage for the gate terminal. PGU output. 10 mV to 4.5 V, 4 digits or 10 mV resolution.
PulseBase	PGU output baseline voltage. -3.0 to 3.0 V, 4 digits or 10 mV resolution. See “Parameters” on page 5-34.
VdStart	Secondary sweep start voltage for the drain terminal. SMU output. -10 V to 10 V, 5 digits or 1 mV resolution.
VdStop	Secondary sweep stop voltage for the drain terminal. SMU output. -10 V to 10 V, 5 digits or 1 mV resolution.
VdStep	Secondary sweep step voltage for the drain terminal. SMU output. -10 V to 10 V, 5 digits or 1 mV resolution.

- VgStart, VgStop, VgStep

The parameters set the primary sweep source used to apply the gate voltage. The number of sweep points is given by the following formula. Then ignore the numbers after the decimal point. If VgStep=0, the measurement voltage is VgStart only.

$$\text{Number of sweep points} = (\text{VgStop} - \text{VgStart}) / \text{VgStep} + 1$$

Pulse amplitude must be > 55 mV and < 4.5 V. So $|\text{VgStart} - \text{PulseBase}|$ and $|\text{VgStop} - \text{PulseBase}|$ must be > 55 mV and < 4.5 V.

To use the gate voltage automatic adjustment function, set the pulse amplitude to < 4.0 V.

- VdStart, VdStop, VdStep

The parameters set the secondary sweep source used to apply the drain voltage. The number of sweep points is given by the following formula. Then ignore the numbers after the decimal point. If VdStep=0, the measurement voltage is VdStart only.

$$\text{Number of sweep points} = (\text{VdStop} - \text{VdStart}) / \text{VdStep} + 1$$

Extended Test Parameters

The following parameters are available to set the test condition. For more details, see “Parameters” on page 5-34.

TransTime	Pulse leading/trailing edge transition time, in s. 2 ns to 500 ns, 3 digits or 1 ns resolution. For the 81101A, minimum value is 5 ns. For the 81150A, minimum value is 2.5 ns when the following conditions are satisfied, or 7.5 ns. <ul style="list-style-type: none">• Pulse amplitude is 2.5 V or less.• Both pulse base and top are within ± 2.5 V.
MeasTime	Measurement timing at the pulse top. 0 to 1, 3 digits or 0.01 resolution.
SmplNum	Oscilloscope sampling number. 16 to 262144, 6 digits or 1 step.
SmthNum	Oscilloscope smoothing number. 3 to 4001, 4 digits or 1 step.
SmthStat	Status of the oscilloscope smoothing. Enable or Disable.
AvgNum	Oscilloscope averaging number. 1 to 4095, 4 digits or 1 step.
VdAdjust	Status of the drain voltage automatic adjustment. Enable or Disable.
VgAdjust	Status of the gate voltage automatic adjustment. Enable or Disable.
RangingMode	Measurement ranging mode. Auto or Fixed.
ConnectChk	Status of the connection check at initialization. Enable or Disable.
GateZero	Status of the gate monitor channel zero measurement at initialization. Enable or Disable.
DcSwitch	Pulse/dc switch units. Yes (exists, pulsed IV measurement connection will be automatically made) or No (none).
SWAddress	GPIB address of the switch controller. Integer, 1 to 32.

PLSDIV Test Definitions
 PLSDIV IdVg, PLSDIV IdVg [2]

Test Output

The following output parameters are displayed after the test.

Vgate	Target gate voltage V_g , in V.
Idrain	Drain current I_d , in A.
VgMon	Gate voltage, in V. Oscilloscope monitor value.
VgConv	Convergence result of the gate voltage automatic adjustment.
Vdrain	Target drain voltage V_d , in V.
VdSet	Drain voltage, in V. SMU output value.
VdInt	Drain voltage, in V. Oscilloscope monitor value.
VdConv	Convergence result of the drain voltage automatic adjustment.
IdPerWg	Drain current per unit gate width, in $A/\mu m$. $IdPerWg = I_d / W_g$

V_gMon , V_dInt , and I_d values will be the value obtained at the data extraction timing on the pulse top. See Figure 5-9.

V_dConv and V_gConv returns 0 (convergence condition is satisfied) or -1 (not satisfied). If the automatic adjustment is OFF, 0 is returned.

If the drain voltage automatic adjustment function is ON, V_dInt will be close to V_d . And if the function is OFF, V_dSet will be close to V_d .

If the gate voltage automatic adjustment function is ON, V_gMon will be close to V_g . And if the function is OFF, $V_{pgu-out}$ will be close to V_g .

Figure 5-5

Test Output Parameters

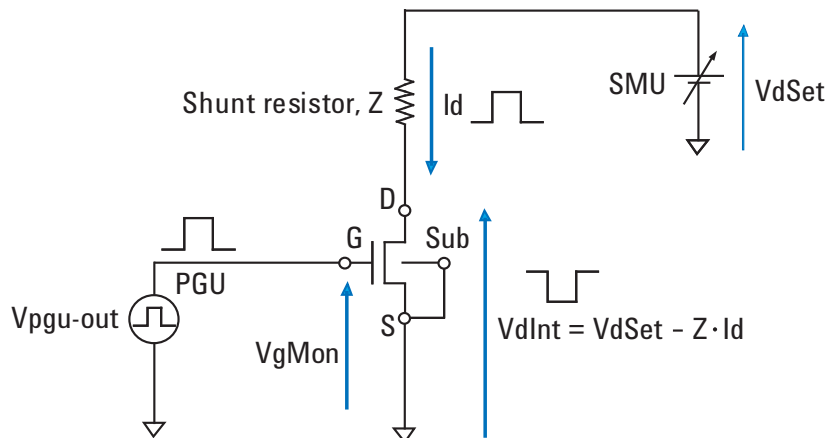

PLSDIV IV SMU

This test definition controls SMUs to apply the primary and secondary sweep voltage, measures current, and displays the I-V characteristics.

Device Parameters The following parameter is available to set the test condition.

IDispRange Maximum value of the Y1 axis, in A. 1 mA to 100 mA, 6 digits or 1 fA resolution.

Test Parameters The following parameters are available to set the source output.

SMU1 Channel number of the SMU used for the primary sweep source. Slot1 to Slot8. Maximum channel number depends on the configuration of DC source monitor.

StartV1 Primary sweep start voltage. -100 to 100 V, 6 digits or 1 μ V resolution.

StopV1 Primary sweep stop voltage. -100 to 100 V, 6 digits or 1 μ V resolution.

StepV1 Primary sweep step voltage. -100 to 100 V, 6 digits or 1 μ V resolution.

Comp1 Primary sweep current compliance, in A. -100 mA to 100 mA, 6 digits or 1 fA resolution.

- StartV1, StopV1, StepV1

The parameters set the primary sweep source used to apply the drain voltage. The number of sweep points is given by the following formula. Then ignore the numbers after the decimal point. If StepV1=0, the measurement voltage is StartV1 only.

$$\text{Number of sweep points} = (\text{StopV1} - \text{StartV1}) / \text{StepV1} + 1$$

- StartV2, StopV2, StepV2

The parameters set the secondary sweep source used to apply the gate voltage. The number of sweep points is given by the following formula. Then ignore the numbers after the decimal point. If StepV2=0, the measurement voltage is StartV2 only.

$$\text{Number of sweep points} = (\text{StopV2} - \text{StartV2}) / \text{StepV2} + 1$$

PLSDIV Test Definitions

PLSDIV IV SMU

SMU2	Channel number of the SMU used for the secondary sweep source. Slot1 to Slot8. Maximum channel number depends on the configuration of DC source monitor.
StartV2	Secondary sweep start voltage. -100 to 100 V, 6 digits or 1 μ V resolution.
StopV2	Secondary sweep stop voltage. -100 to 100 V, 6 digits or 1 μ V resolution.
StepV2	Secondary sweep step voltage. -100 to 100 V, 6 digits or 1 μ V resolution.
Comp2	Secondary sweep current compliance, in A. -100 mA to 100 mA, 6 digits or 1 fA resolution.
Hold	Hold time, in s. 0 to 10. 4 digits or 1 ms resolution.
Delay	Delay time, in s. 0 to 1. 5 digits or 1 ms resolution.
MeasCh	Channel number of the SMU used for the current measurement. Slot1 to Slot8. Maximum channel number depends on the configuration of DC source monitor.
RangeMode	Current measurement ranging mode. Auto, LimitedAuto, or Fixed.
MeasRange	Current measurement range. 10 pA to 100 mA. 6 digits or 10 pA resolution. Available measurement range depends on the type of SMU.
ADCType	Only for the E5260/E5270 series. Type of A/D converter. HighSpeed or HighResolution
IntegMode	Only for the E5260/E5270 series. Integration mode. Auto, Manual, or PLC.
IntegNum	For E5260/E5270, this parameter is the coefficient used to define the integration time or the number of averaging samples for the current measurement. Integer. See Table 5-2. For 4155/4156, this parameter is the number of averaging samples if this value is positive, or the NPLC value if this value is negative. Integer, -1023 to 1023. IntegNum=-1023 to -101 give the same result as IntegNum=-100. The NPLC means the number of power line cycles for the current measurement.

Extended Test Parameters

The following parameters are available to set the test condition.

- SMUType** Type of DC source monitor. E526x, E527x, or FLEX415x.
E526x: for Agilent E5260A
E527x: for Agilent E5270B
FLEX415x: for Agilent 4155/4156
- AddrGPIB** GPIB address of the DC source monitor. Integer, 1 to 32.

Test Output

The following output parameters are displayed after the test.

- SweepV1** Primary sweep source output data, in V. This is the X axis data of the X-Y graph.
- SweepV2** Secondary sweep source output data, in V.
- IMeas1** Current measurement data, in A. This is the Y1 axis data of the X-Y graph.

PLSDIV Test Definitions
 PLSDIV IV SMU

Table 5-2 Integration Time Setup Parameters for E5260/E5270

ADCType	IntegMode	IntegNum
HighSpeed	Auto	Value that defines the number of averaging samples given by the following formula. 1 to 1023. <i>Number of averaging samples = IntegNum × system-defined-value</i> where <i>system-defined-value</i> is the number of averaging samples automatically set by the E5260/E5270.
	Manual	Number of averaging samples. 1 to 1023.
	PLC	Value that defines the number of averaging samples given by the following formula. 1 to 100. <i>Number of averaging samples = IntegNum × 128</i> The E5260/E5270 gets 128 samples in a power line cycle, repeats this for the times you specify, and performs averaging to get the measurement data.
HighResolution	Auto	Value that defines the integration time given by the following formula. 1 to 127. <i>Integration time = IntegNum × system-defined-value</i> where <i>system-defined-value</i> is the integration time automatically set by the E5260/E5270.
	Manual	Value that defines the integration time given by the following formula. 1 to 127. <i>Integration time = IntegNum × 80 μsec</i>
	PLC	Value that defines the integration time given by the following formula. 1 to 100. <i>Integration time = IntegNum / power line frequency</i>

PLSDIV Reset

This test definition resets and initializes the pulsed IV test system.

Device Parameters None

Test Parameters None

Extended Test Parameters None

Test Output None

PLSDIV Setup

This test definition is used to perform the system setup and the compensation of the pulsed IV test system. Select the action in the Actions field, set the extended parameters, and click the Single button to perform the action.

All instruments must be connected by GPIB cables before starting the system setup.

Device Parameters None

Test Parameters The following parameters must be set to perform the system setup.

DcSwitch Set Yes to use the pulse/dc switch. Do not set No.

Actions Actions available for the pulsed IV system setup.

- System Configuration
- Compensation
- Skew Measurement
- Drain Cable Replacement
- Pgu Compensation

For the actions, see “Pulsed IV System Setup” on page 3-3.

Extended Test Parameters

Set the switch controller GPIB address to the SWAddress field. The other fields are only for the Pgu Compensation action.

SWAddress GPIB address of the switch controller. Integer, 1 to 32.

PulseBase Only for Pgu Compensation. PGU output baseline voltage. -3.0 to 3.0 V, 4 digits or 10 mV resolution.

TransTime Only for Pgu Compensation. Pulse leading/trailing edge transition time, in s. 2 ns to 500 ns, 3 digits or 1 ns resolution.

For the 81101A, minimum value is 5 ns.

For the 81150A, minimum value is 2.5 ns when the following conditions are satisfied, or 7.5 ns.

- Pulse amplitude is 2.5 V or less.
- Both pulse base and top are within ± 2.5 V.

MeasTime Only for Pgu Compensation. Measurement timing at the pulse top. -1 to 1, 3 digits or 0.01 resolution.

For more details of the parameters, see “Parameters” on page 5-34.

Test Output None

Parameters

This section explains the definitions of the parameters used in the pulsed IV test definitions.

Polarity

Polarity controls the source output polarity. Usually, a positive polarity is used for the N channel devices and a negative polarity is used for the P channel devices.

Figure 5-6 shows the polarity of gate pulse voltage.

DeviceDelay

DeviceDelay defines the delay time set to the oscilloscope and used to compensate a skew caused by the device under test. This is important to synchronize the gate pulse and the drain pulse. Check the pulse waveform and read the delay time between the gate pulse and the drain pulse.

Figure 5-6

Polarity

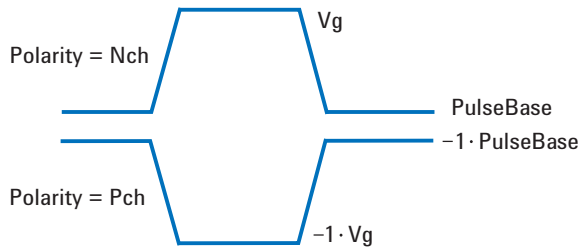
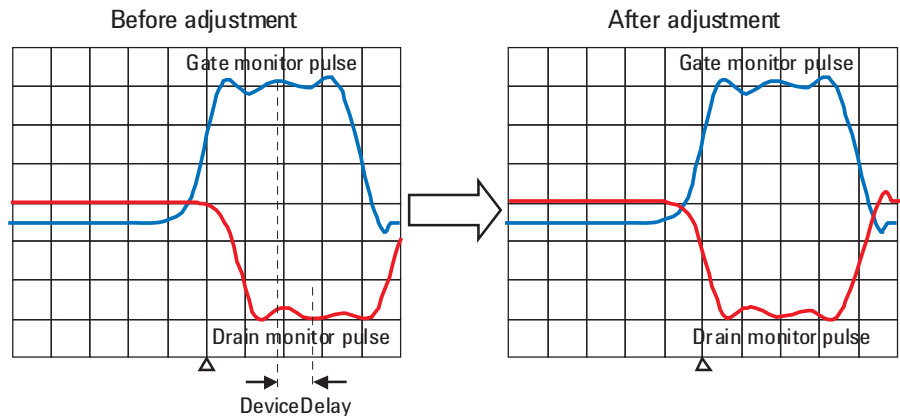

Figure 5-7

DeviceDelay



PulseWidth PulseWidth is the width of the gate pulse and defined as shown in Figure 5-8.

PulseBase PulseBase is the baseline voltage of the gate pulse and defined as shown in Figure 5-8. The value must be low enough to turn off the device under test.

If you set PulseBase \neq 0 V, enable the gate voltage automatic adjustment function to obtain the stable gate pulse voltage. See “VgAdjust” on page 5-38.

Pulse amplitude must be $>$ 55 mV and $<$ 4.5 V. To use the gate voltage automatic adjustment function, set the pulse amplitude to $<$ 4.0 V.

TransTime TransTime is the gate pulse transition time for both leading and trailing edges and defined as shown in Figure 5-8. Initially, this value is set to 2 ns. Changing this value may cause a measurement error.

Figure 5-8 TransTime, PulseWidth, and PulseBase

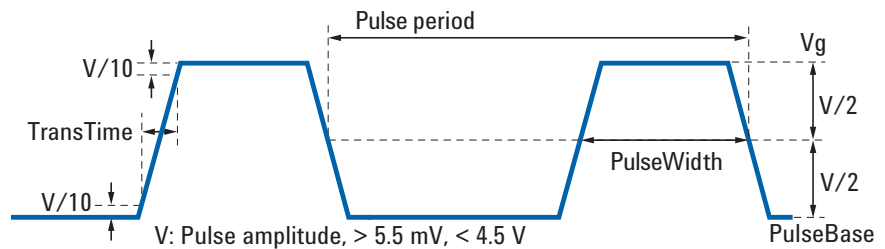

PLSDIV Test Definitions Parameters

MeasTime

MeasTime defines the data extraction timing (see Figure 5-9) which is the timing to extract the pulsed IV measurement data (gate voltage, drain voltage, and drain current) from the oscilloscope measurement result (pulse waveform). Initially, this value is set to 0.5. Changing this value may cause a measurement error. If you change this value, check the pulse waveform and choose the point where the pulse voltage is flat and stable.

Figure 5-9

MeasTime

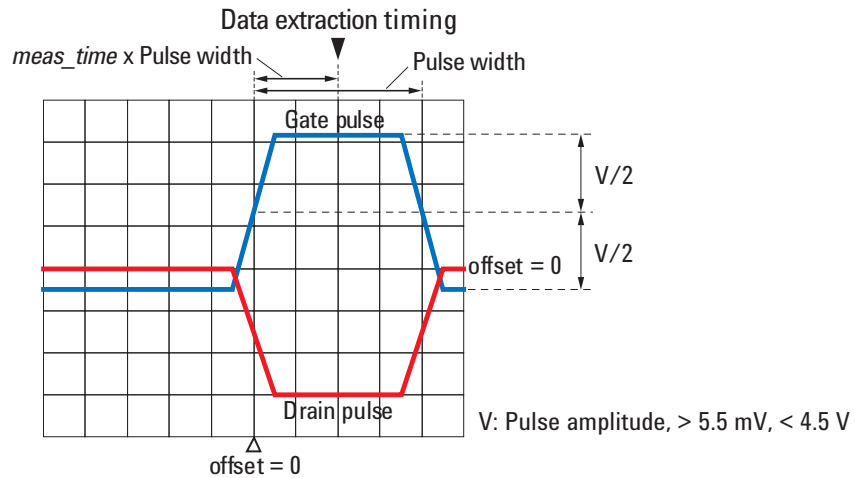

SmplNum

SmplNum defines the sampling number set to the oscilloscope. Set the value in order to display the pulse waveform on the oscilloscope screen. A small number will improve measurement throughput.

Sampling rate of the oscilloscope is set to the value automatically calculated from the specified pulse width and the specified sampling number.

SmthNum SmthNum defines the number of measurement points used for the smoothing function of oscilloscope. SmthNum must be less than SmplNum.

SmthStat SmthStat sets the smoothing function ON or OFF of the oscilloscope.
The smoothing function averages the time-series data to reduce variations caused by high-frequency components. Set the value in order to display the pulse waveform on the oscilloscope screen. A too large number of smoothing points loses waveform edges, which disturbs accurate results.

Figure 5-10 Smoothing Function

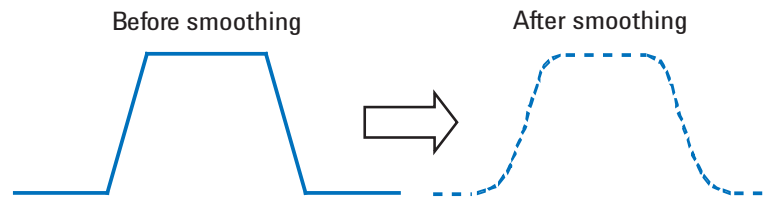

AvgNum AvgNum specifies the measurement averaging number set to the oscilloscope. The scope measures pulse waveform the specified number of times and displays the averaged pulse waveform. A large number reduces random noise and increases sharpness of waveform.

PLSDIV Test Definitions Parameters

VdAdjust

VdAdjust sets the drain voltage automatic adjustment function ON or OFF. This function is used to compensate the voltage drop caused by the shunt resistor. See Figure 5-11. When this function is OFF, the SMU applies Vd (specified drain voltage). When this function is ON, the SMU output level will be automatically controlled so that Vd is applied to the drain terminal.

If you do not mind the effect of the shunt resistor, set this function OFF. This brings higher measurement throughput.

VgAdjust

VgAdjust sets the gate voltage automatic adjustment function ON or OFF. This function is used to obtain stable gate voltage. When this function is OFF, the PGU applies Vg (specified gate voltage). When this function is ON, the PGU output level will be automatically controlled so that Vg is applied to the gate terminal.

If you do not mind the stability of the gate voltage, set this function OFF. This brings higher measurement throughput.

If you set PulseBase <> 0 V, set this function ON.

To use this function, set the pulse amplitude to < 4.0 V.

Figure 5-11

VdAdjust and VgAdjust

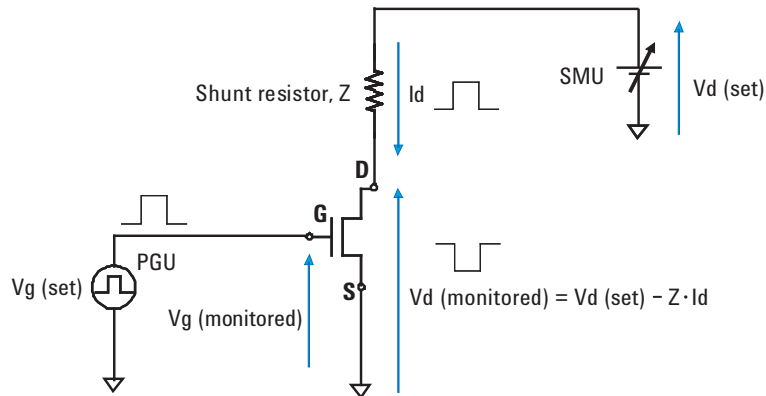

- RangingMode** RangingMode defines the measurement ranging mode set to the oscilloscope.
- Auto ranging uses the best measurement range for the monitor value automatically. The maximum range is the best range for the specified IdMax value.
- Fixed ranging uses the best range for the specified IdMax value. This mode contributes to higher measurement throughput.
- ConnectChk** ConnectChk sets the connection check function ON or OFF. This function is used to confirm if the divider, terminator, and bias-T are connected properly. For the correct connections, see “PlsdivInit” on page 6-15. The connection check can detect the following improper connections.
- divider is not connected
 - terminator is not connected
 - T-adaptor is connected instead of divider
 - bias-T’s DC+RF connector is connected to the gate monitor channel
- GateZero** GateZero sets the gate monitor channel zero measurement ON or OFF. This function is used to measure the offset data of the gate voltage monitor path and update the offset value stored in a system file.
- Before performing the offset measurement, the measurement cables must be connected properly and the cable ends must be opened.
- DcSwitch** DcSwitch is used to declare the usage of the pulse/dc switch units. The value must be Yes only when the switch units are used.
- The switch units are used to switch the pulsed IV measurement connection and the DC IV measurement connection automatically. If DcSwitch=Yes, the pulsed IV measurement connection will be made initially.
- SWAddress** GPIB address of the switch controller. Integer, 1 to 32.
- If DcSwitch=Yes, enter the GPIB address of the switch controller to this field correctly.

PLSDIV Test Definitions
Parameters

PLSDIV TIS Commands

This chapter provides reference information of the pulsed IV .exe library (Plsdiv commands, PLSDIV TIS) used in the PLSDIV application test definitions. This chapter consists of the following sections.

- “Command Summary”
- “Entering Plsdiv Commands”
- “Command Reference”

NOTE

This chapter uses the following conventions.

<system drive>: Drive the pulsed IV system software is installed

<program folder>: Following folder

For Windows 7 64 bit version, <system drive>:\Program Files (x86)

For B1500A, Windows 7 32 bit version, and Windows XP,
<system drive>:\Program Files

NOTE

The Plsdiv commands are stored in the following folder.

<program folder>\Agilent\PLSDIV\PLSDIVExe\TISExe

To execute the Plsdiv commands, all of the required files must be installed properly. See “Software Installation” on page 2-16.

Command Summary

The pulsed IV .exe library (Plsdiv commands) is summarized in Table 6-1.

When using the Plsdiv commands, the execution sequence of commands must be as shown in Figure 6-1. PlsdivInit command must be executed at the beginning of the measurement and PlsdivUninit command must be executed at the end of the measurement. The Plsdiv commands are only effective between PlsdivInit and PlsdivUninit commands.

Command execution must be completed with no error before executing a subsequent command. For example, the PlsdivMeasureId command must complete normally before the PlsdivCaptureMonData command can be executed.

NOTE

PlsdivUninit makes all Plsdiv commands inexecutable. Execute PlsdivInit to use the Plsdiv commands.

PlsdivCutoffVd makes PlsdivMeasureId inexecutable. Execute PlsdivForceVd before PlsdivMeasureId.

PlsdivCutoffVg makes PlsdivMeasureId inexecutable. Execute PlsdivForceVg before PlsdivMeasureId.

Figure 6-1 Plsdiv Command Execution Sequence

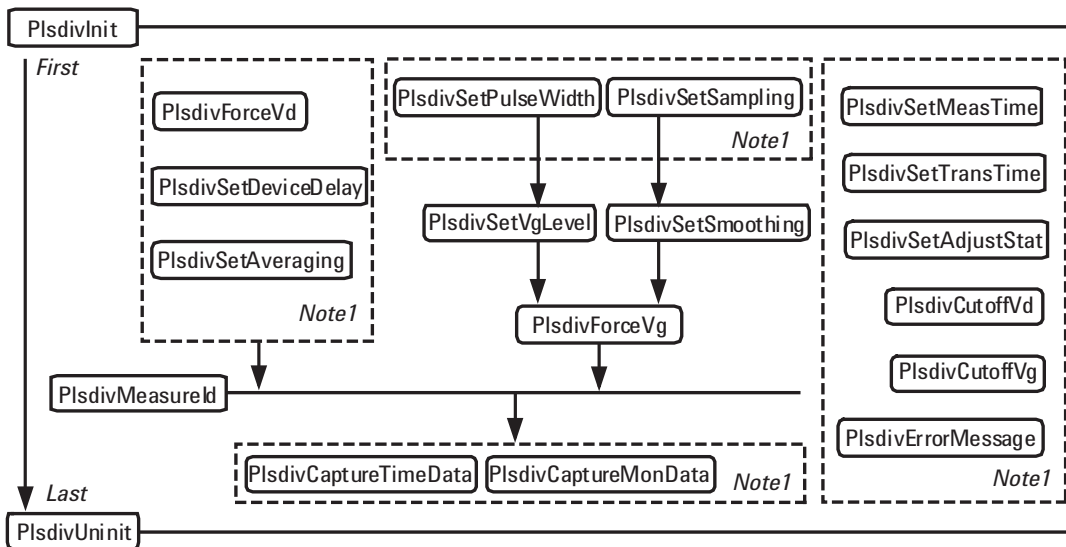

Note1: No condition in the execution sequence between commands in this box

PLSDIV TIS Commands

Table 6-1 **Plsdiv Command Summary**

Command	Summary
PlsdivInit	Initializes the pulsed IV test system. Must be executed before any other Plsdiv command.
PlsdivForceVd	Sets the SMU (source monitor unit) output switch on and applies the specified drain voltage.
PlsdivSetDeviceDelay	Sets the device delay time between the gate pulse and the drain pulse.
PlsdivSetAveraging	Sets the oscilloscope averaging number for the pulsed IV measurement.
PlsdivSetMeasTime	Changes the timing for extracting the pulsed IV measurement data (optional).
PlsdivSetTransTime	Changes the pulse transition time of the gate voltage (optional).
PlsdivSetAdjustStat	Enables or disables the automatic output adjustment of the specified source.
PlsdivCutoffVd	Applies a 0 V drain voltage and sets the SMU output switch off.
PlsdivCutoffVg	Sets the PGU (pulse generator unit) output switch off.
PlsdivErrorMessage	Returns the error number and error message for the specified status code.
PlsdivSetSampling	Sets the oscilloscope sampling rate and sampling number for the pulsed IV measurement.
PlsdivSetSmoothing	Enables or disables smoothing of the specified oscilloscope channel.
PlsdivSetPulseWidth	Sets the pulse width of the gate voltage.
PlsdivSetVgLevel	Sets the pulse level and polarity of the gate voltage.
PlsdivForceVg	Sets the PGU output switch on and starts the gate voltage output.
PlsdivMeasureId	Performs the pulsed IV measurement and returns the measurement result. This performs drain voltage spot measurement and calculates the current value.
PlsdivCaptureTimeData	Reads the oscilloscope horizontal data (time data) after PlsdivMeasureId.
PlsdivCaptureMonData	Reads the oscilloscope vertical data (monitor data) after PlsdivMeasureId.
PlsdivUninit	Resets the pulsed IV test system.
DispMessage	Opens a pop-up window and displays the specified string.

Entering Plsdiv Commands

Plsdiv commands can be entered by input from the Windows Command Execution component on the Test Definition window's Test Contents tab screen (see "Setup Example" on page 6-8). Most Plsdiv commands need parameters to be sent or returned. The parameters will be variables that can be defined on the Test Specification tab screen or the Local Variable Definition component on the Test Contents tab screen. This section describes how to enter the Plsdiv commands.

- "Command Parameters"
- "Defining Numeric/Vector Input Parameter"
- "Defining String/Numeric Input Parameters"
- "Defining Numeric Output Parameter"
- "Defining Vector Output Parameter"
- "Defining String Output Parameter"
- "Defining Format Field"

Command Parameters

The Windows Command Execution component supports one input variable and one output variable. To use multiple string input parameters or multiple numeric input parameters, set the variable as shown below. Multiple vector input parameters and multiple output parameters are not supported.

- If the command requires multiple string input parameters, use string variables. In the Windows Command Execution component, set the Write Type to String. Up to 20 string data can be defined.
- If the command requires multiple numeric input parameters, use numeric variables and set the Write Type to String. To enter the numeric variable name, use the *string* built-in function. For example, enter `string(Rz)` to set the Rz numeric variable.
- If the command requires both numeric and string input parameters, use numeric and string variables respectively, and set the Write Type to String.

NOTE

Before calling the command, enter the value to the input variable by using the ASSIGN statement.

Defining Numeric/Vector Input Parameter

1. Define a vector variable in the Test Specification tab screen or the Local Variable Definition component of the Test Contents tab screen.
2. Set the Write Type to List in the Windows Command Execution component.
3. Enter the variable name in the Values field of the Write List area.

For the numeric parameter, a data element of vector variable is used to store the data for the parameter. Specify the data by using the Format field. For example, enter { 0 } to specify the data in the first element of the vector variable. For the Format field, see “Defining Format Field” on page 6-7.

For the vector parameter, ignore the Format field.

Defining String/Numeric Input Parameters

1. Define string or numeric variables in the Test Specification tab screen or the Local Variable Definition component in the Test Contents tab screen.
2. Set the Write Type to String in the Windows Command Execution component.
3. Add a line in the Write String area.
4. Enter the variable name for the first parameter in the first line.

If the command needs multiple input parameters, add a line and enter the variable name for the variable in the added line. Then observe the order of parameters.

To enter a numeric variable name, use the *string* built-in function. For example, enter `string(Rz)` to set the Rz numeric variable.

Defining Numeric Output Parameter

1. Define a numeric variable in the Test Specification tab screen or the Local Variable Definition component of the Test Contents tab screen.
2. Set the Read Type to Value in the Windows Command Execution component.
3. Enter the variable name in the Value field of the Read Value area.

The Result field can be blank or the name of another numeric variable defined in the Test Specification or Local Variable Definition. The variable will be used to receive the command execution result.

Defining Vector Output Parameter

1. Define a vector variable in the Test Specification tab screen or the Local Variable Definition component of the Test Contents tab screen.
2. Set the Read Type to List in the Windows Command Execution component.
3. Enter the variable name in the Values field of the Read List area.

The Result field can be blank or the name of a numeric variable defined in the Test Specification or Local Variable Definition. The variable will be used to receive the command execution result.

Defining String Output Parameter

1. Define a string variable in the Test Specification tab screen or the Local Variable Definition component of the Test Contents tab screen.
2. Set the Read Type to String in the Windows Command Execution component.
3. Enter the variable name in the String field of the Read String area.

The Result field and the Length Actually Read field can be blank or the name of a numeric variable defined in the Test Specification or Local Variable Definition. The variable will be used to receive the command execution result or the length of the returned string data.

Defining Format Field

The Format field requires a keyword to specify a data in vector variable. The keyword must have the style such as {I,A:F}. where,

- I** Index used to specify the element. Integer, 0 or positive number. Mandatory. 0 specifies the first element.
- A** Character length of the specified data element. Positive integer for right-aligned, or negative integer for left-aligned. If this value is not set, the length is not specified (no limit).
- F** Style of the data. See Table 6-2. If this value is not set, G is selected..

Following are the example formats. For more information, see online help or manual of Agilent T&M Programmers Toolkit.

- {0,5:E} First element, five characters, exponential notation
- {1,10} Second element, 10 characters, general

PLSDIV TIS Commands

Setup Example

- {2:x} Third element, no limit for length, hexadecimal numeric
- {3} Fourth element, no limit for length, general

Table 6-2

Available F values

F	Meaning	F	Meaning
C or c	Circulation	N or n	Numeric
D or d	Decimal numeric	P or p	Percent
E or e	Exponential notation	R or r	Round trip
F or f	Fixed point	X or x	Hexadecimal numeric
G or g	General		

Setup Example

The following example setup is used to execute a `PlsdivMeasureId` command that has two numeric inputs and four numeric outputs.

ranging and *id_range* are numeric variables used for the input parameters, *read_data* is a vector variable used for the output parameters, and *PassFail* is a numeric variable used to store the command execution result. They must be defined in the Test Specification tab screen or the Local Variable Definition component on the Test Contents tab screen. Input parameter values must be set to the variables before executing the command. Four data will be assigned to *read_data* in sequence.

Table 6-3

Windows Command Execution Setup Example

Windows Command Execution							
Command Filename:	C:\Program Files\Agilent\PLSDIV\PLSDIVExe\TISExe\PlsdivMeasureId.exe						
Argument:							
Write Type:	x	String		List			
Read Type:		String		Value	x	List	None
Write String							
	string(ranging)						
	string(id_range)						
Read List							
Result:	PassFail			Values:	read_data		

Command Reference

This section contains detailed descriptions of all the Plsdiv commands. The commands are listed in alphabetical order. Each entry:

1. Gives one command
2. Describes the execution conditions, if any exists
3. Describes the file name to be entered in the Command Filename field
4. Describes the Write Type and Read Type settings that must be set when using the command
5. Describes the argument to be input in the Argument field, if it exists
6. Lists the input parameters (Write String or Write List) that must be sent to the command, if any exists
7. Lists the output parameters (Read String, Read Value, or Read List) returned by the command, if any exists
8. Describes the response (execution result) returned by the command and can be read by using the Result field of the Read String/Value/List area, if it exists
9. Explains any additional information

NOTE

The Plsdiv commands are stored in the following folder.

<program folder>\Agilent\PLSDIV\PLSDIVExe\TISExe

NOTE

The Plsdiv commands can be defined in the Windows Command Execution component on the Test Definition window's Test Contents tab screen.

Most of the Plsdiv commands need parameters to be sent or to be returned. The parameters will be variables that can be defined in the Test Specification tab screen or the Local Variable Definition component on the Test Contents tab screen.

DispMessage

This command opens a pop-up window and displays the specified string. This command can be executed without the PlsdivInit command.

Filename DispMessage.exe

Write Type String

Read Type None

Write String This command needs the following input parameter.

message Specify a message to display in the pop-up window.

PlsdivCaptureMonData

This command reads the oscilloscope vertical data (monitor data). It returns the gate voltage data, drain voltage data, or drain current data selected by the *term* and *drain_mode* parameters.

Execution Conditions

PlsdivSetSampling and PlsdivMeasureId must be executed before this command.

The PlsdivSetSampling command *sampling_num* parameter value must not be 0.

Filename

PlsdivCaptureMonData.exe

Write Type

String

Read Type

List

Write String

This command needs the following input parameters in this sequence.

- term** Terminal. Numeric value, 0 (gate) or 1 (drain).
- sampling_num** Sampling number of oscilloscope. Numeric value, 16 to 262144. The value must be the same as the *sampling_num* parameter value set to the PlsdivSetSampling command.
- drain_mode** Drain data type. Numeric value, 0 (voltage) or 1 (current).

If *term*=0, this command returns the gate voltage data.

If *term*=1 and *drain_mode*=0, this command returns the drain voltage data.

If *term*=1 and *drain_mode*=1, this command returns the drain current data.

Read List

This command returns the following output parameter.

- read_data** Oscilloscope vertical data (monitor data). Vector data. The number of returned data is *sampling_num* if the smoothing is off or the number of data displayed on the oscilloscope screen if the smoothing is on. The smoothing on/off is set by the PlsdivSetSmoothing command.

Response

Number of returned data. Numeric value.

PlsdivCaptureTimeData

This command reads the oscilloscope horizontal data (time data).

Execution Conditions

PlsdivSetSampling and PlsdivMeasureId must be executed before this command.

The PlsdivSetSampling command *sampling_num* parameter value must not be 0.

Filename

PlsdivCaptureTimeData.exe

Write Type

String

Read Type

List

Write String

This command needs the following input parameter.

sampling_num Sampling number of oscilloscope. Numeric value, 16 to 262144. The value must be the same as the *sampling_num* parameter value set to the PlsdivSetSampling command.

Read List

This command returns the following output parameter.

read_data Oscilloscope horizontal data (time data). Vector data. The number of returned data is *sampling_num* if the smoothing is off or the number of data displayed on the oscilloscope screen if the smoothing is on. The smoothing on/off is set by the PlsdivSetSmoothing command.

Response

Number of returned data. Numeric value.

PlsdivCutoffVd

This command applies 0 V drain voltage and sets the SMU output switch off.

Filename	PlsdivCutoffVd.exe
Response	Status code. Numeric value. To read error message, use PlsdivErrorMessage. If no error is detected by this command execution, 0 is returned.

PlsdivCutoffVg

This command sets the PGU output switch off.

Filename	PlsdivCutoffVg.exe
Response	Status code. Numeric value. To read the error message, use PlsdivErrorMessage. If no error is detected by this command execution, 0 is returned.

PlsdivErrorMessage

This command returns the error number and error message for the specified status code. For the error code and message, see “Status Code and Error Messages” on page 7-1.

Filename	PlsdivErrMessage.exe
Write Type	String
Read Type	String
Write String	This command needs the following input parameter. status_code Status code returned by a command. Numeric value.
Read String	This command returns the following output parameter. message Error message specified by the <i>status_code</i> parameter. The message is a string up to 256 characters.
Response	Error number specified by the <i>status_code</i> parameter. Numeric value.

PlsdivForceVd

This command sets the SMU (source monitor unit) output switch on and applies the specified drain voltage.

Filename	PlsdivForceVd.exe
Write Type	String
Read Type	String. However, this command does not return any output parameter.
Write String	This command needs the following input parameter. vd Drain voltage in V. Numeric value, -10 to 10.
Response	Status code. Numeric value. To read the error message, use PlsdivErrorMessage. If no error is detected by this command execution, 0 is returned.

PlsdivForceVg

This command sets the PGU (pulse generator unit) output switch on, applies the gate voltage pulse, and returns the gate voltage monitor value.

Execution Conditions	PlsdivSetPulseWidth and PlsdivSetVgLevel commands must be executed before this command in this sequence.
Filename	PlsdivForceVg.exe
Write Type	String. However, this command does not need any input parameter.
Read Type	List
Read List	This command returns the following output parameters in this sequence. To read the values, specify a vector variable in the Values field of the ReadList area. The values are stored in the first and second elements of the vector variable. vg_mon Gate voltage monitor value that is the actual gate voltage monitored by the oscilloscope. Numeric value, in V. conv_stat Convergence result of the gate voltage automatic adjustment. Numeric value, 0 (convergence condition is satisfied) or -1 (not satisfied). If the automatic adjustment is off, 0 is returned. The convergence condition is a system parameter, no user definable.

Auto Adjustment This function is set by the PlsdivSetAdjustStat command, and is used to adjust the gate voltage automatically so that the *vg_mon* value is close to the *vg_high* value specified by the PlsdivSetVgLevel command.

Response Status code. Numeric value. To read the error message, use PlsdivErrorMessage. If no error is detected by this command execution, 0 is returned.

PlsdivInit

This command initializes the pulsed IV test system. This command must be executed before any other Plsdiv command.

Filename PlsdivInit.exe

Write Type String

Read Type String. However, this command does not return any output parameter.

Write String This command needs the following input parameters in this sequence.

connect_check Connection check status. Numeric value, 0 (does not perform) or 1 (performs connection check in the PlsdivInit process).

gate_zero Gate zero status. Numeric value, 0 (does not perform) or 1 (performs gate monitor channel offset measurement in the PlsdivInit process).

Gate Zero This function is used to measure the offset data of the gate voltage monitor path and update the offset value in a system file. The offset value is used until the next execution. Before performing the offset measurement, set up the test system measurement path properly and open the measurement terminals.

Connection Check This function is used to confirm if the divider, terminator, and bias-T are connected properly. For the proper connections, see Figure 6-2 and Figure 6-3. The connection check can detect the following improper connections.

- divider is not connected
- terminator is not connected
- T-adpater is connected instead of divider
- bias-T's DC+RF connector is connected to the gate monitor channel

PLSDIV TIS Commands

PlsdivInit

If this function detects an improper connection, a nonzero status code will be returned.

Figure 6-2 Divider and Terminator connection

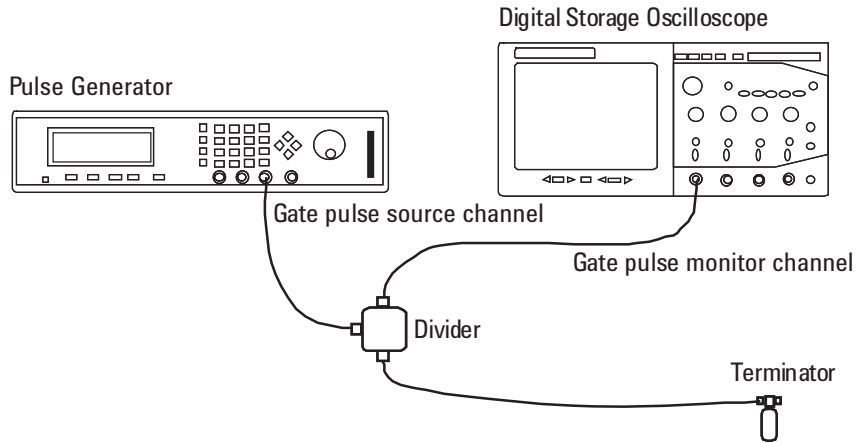
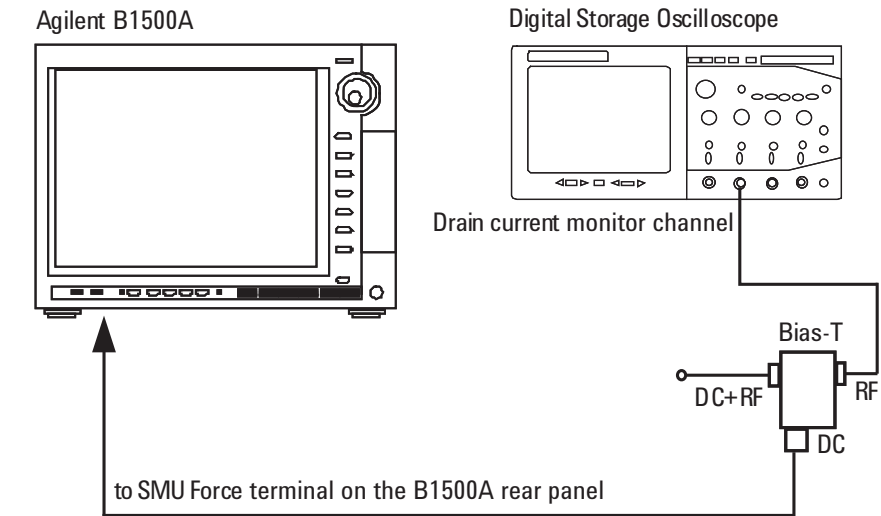

Figure 6-3 Bias-T connection



Response

Status code. Numeric value. To read the error message, use PlsdivErrorMessage. If no error is detected by this command execution, 0 is returned.

PlsdivMeasureId

This command performs the pulsed IV measurement and returns the measurement result. This performs drain voltage spot measurement and calculates current value.

Filename	PlsdivMeasureId.exe
Write Type	String
Read Type	List
Write String	This command needs the following input parameters in this sequence. ranging Measurement ranging mode. Numeric value, 0 (auto ranging) or 1 (fixed ranging). id_range Drain current range, in A. Numeric value, 0 to 0.08.
Ranging Mode	Auto ranging uses the best measurement range for the monitor value automatically. The maximum range is the best range for the specified <i>id_range</i> value. Fixed ranging uses the best range for the specified <i>id_range</i> value. This mode will improve measurement throughput.
Read List	This command returns the following output parameters in this sequence. To read the values, specify a vector variable in the Values field of the ReadList area. The values are stored in the first element to the fourth element of the vector variable. id Drain current, calculated from <i>vd_actual</i> . Numeric value, in A. vd_set Drain voltage, SMU output value. Numeric value, in V. vd_actual Drain voltage, oscilloscope monitor value. Numeric value, in V. conv_stat Convergence result of the drain voltage automatic adjustment. Numeric value, 0 (convergence condition is satisfied) or -1 (not satisfied). If the automatic adjustment is off, 0 is returned. The convergence condition is a system parameter, not user-definable.
Auto Adjustment	This function is set by the PlsdivSetAdjustStat command, and is used to adjust the drain voltage automatically so that the <i>vd_actual</i> value is close to the <i>vd</i> value specified by the PlsdivForceVd command.

PLSDIV TIS Commands

PlsdivSetAdjustStat

If this function is off, the *vd_set* value will be equal to the *vd* value specified by the PlsdivForceVd command and the *vd_actual* value will show the value divided by the shunt resistor.

Response Status code. Numeric value. To read the error message, use PlsdivErrorMessage. If no error is detected by this command execution, 0 is returned.

PlsdivSetAdjustStat

This command enables or disables the automatic output adjustment of the specified source, PGU (pulse generator) for the gate voltage or SMU (source monitor unit) for the drain voltage.

Filename PlsdivSetAdjustStat.exe

Write Type String

Read Type String. However, this command does not return any output parameter.

Write String This command needs the following input parameters in this sequence.

term Terminal. Numeric value, 0 (gate) or 1 (drain).

adj_stat Function status. Numeric value, 0 (off) or 1 (on).

Response Status code. Numeric value. To read the error message, use PlsdivErrorMessage. If no error is detected by this command execution, 0 is returned.

PlsdivSetAveraging

This command sets the oscilloscope averaging number for the pulsed IV measurement. Large averaging number contributes high certainty of measurement result and long measurement time.

Filename PlsdivSetAveraging.exe

Write Type String

Read Type String. However, this command does not return any output parameter.

Write String This command needs the following input parameter.

avg_num Averaging number. Numeric value, 1 to 4096.

Response Status code. Numeric value. To read the error message, use PlsdivErrorMessage. If no error is detected by this command execution, 0 is returned.

PlsdivSetDeviceDelay

This command sets the device delay time between the gate pulse and the drain pulse.

Before performing the pulsed IV measurement, figure out the device delay time and set it by using this command. To figure out the device delay time, set up the test system properly, connect the device under test, apply voltage pulse to the gate terminal, and monitor the gate pulse and the drain pulse as shown in Figure 6-4.

Filename PlsdivSetDeviceDelay.exe

Write Type String

Read Type String. However, this command does not return any output parameter.

Write String This command needs the following input parameter.

device_delay Delay time caused by test device, in second. Numeric value, -0.000001 to 0.000001.

Response Status code. Numeric value. To read the error message, use PlsdivErrorMessage. If no error is detected by this command execution, 0 is returned.

Figure 6-4 Adjustment for Device Delay

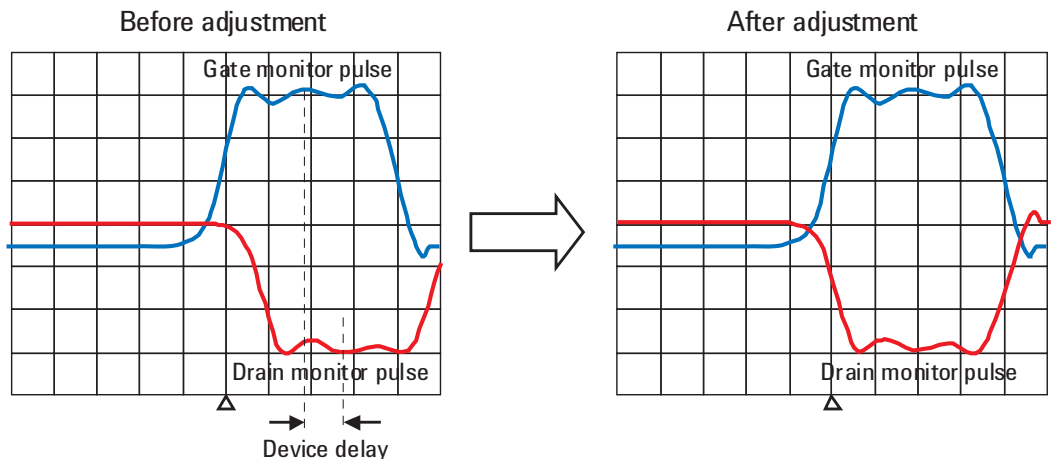

PlsdivSetMeasTime

This command changes the timing for extracting the pulsed IV measurement data (gate voltage, drain voltage, and drain current) from the oscilloscope measurement result (pulse waveform). This change is effective after the PlsdivForceVg command is executed and until the next PlsdivSetMeasTime command or the PlsdivUninit command is executed. This command execution is optional.

Remarks	Changing this value may cause measurement errors.
Filename	PlsdivSetMeasTime.exe
Write Type	String
Read Type	String. However, this command does not return any output parameter.
Write String	This command needs the following input parameter. meas_time Data extraction timing. Numeric value, -1 to 1. Default value is 0.5. The data extraction timing is specified by the rate for the pulse width as shown in Figure 6-5.

Figure 6-5 Data Extraction Timing

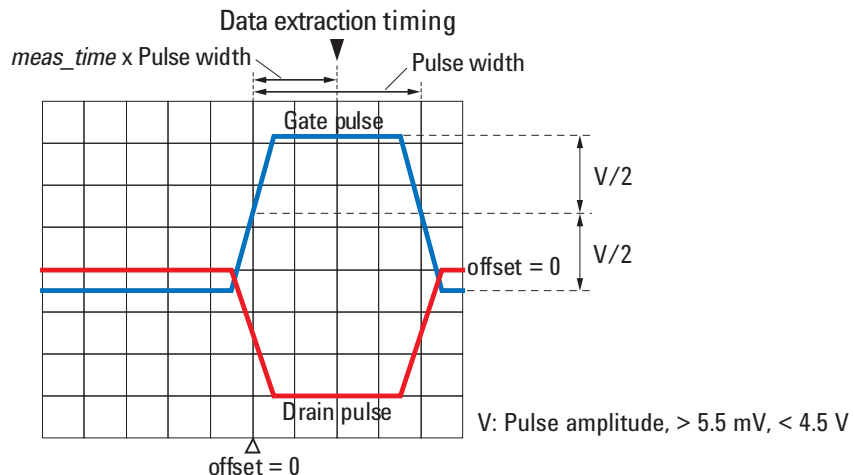

Response	Status code. Numeric value. To read the error message, use PlsdivErrorMessage. If no error is detected by this command execution, 0 is returned.
-----------------	--

PlsdivSetPulseWidth

This command sets the pulse width of the gate voltage.

Filename	PlsdivSetPulseWidth.exe
Write Type	String
Read Type	String. However, this command does not return any output parameter.
Write String	This command needs the following input parameter. pulse_width Pulse width of gate pulse, in second. Numeric value, 10 nsec to 1 μ sec. See Figure 6-6.
Response	Status code. Numeric value. To read the error message, use PlsdivErrorMessage. If no error is detected by this command execution, 0 is returned.

Figure 6-6

Pulse Setup Parameters

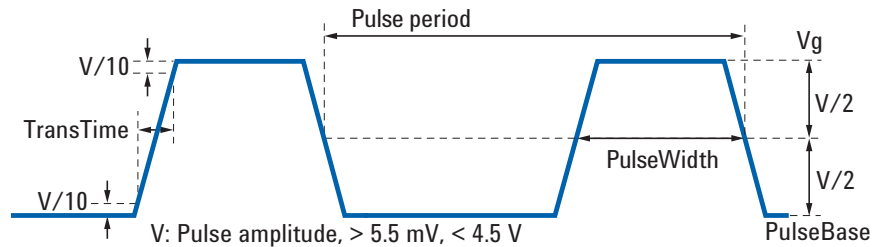

PlsdivSetSampling

This command sets the oscilloscope sampling rate and sampling number for the pulsed IV measurement.

Remarks	Adjust the sampling number and the sampling rate carefully to obtain the waveform you desire. To obtain faster measurement throughput, decrease the sampling number. Too small sampling numbers will cause measurement errors.
Filename	PlsdivSetSampling.exe
Write Type	String
Read Type	String. However, this command does not return any output parameter.

PLSDIV TIS Commands

PlsdivSetSmoothing

Write String

This command needs the following input parameters in this sequence.

- sampling_rate** Sampling rate. Numeric value, 0 (auto), 1 to 20 G [times/sec]. It is difficult to find the optimum value. Set *sampling_rate*=0 for an easy setup.
- sampling_num** Total number of sampling. Numeric value, 0 (auto), 16 to 262144.

Response

Status code. Numeric value. To read the error message, use PlsdivErrorMessage. If no error is detected by this command execution, 0 is returned.

PlsdivSetSmoothing

This command enables or disables smoothing of the specified oscilloscope channel.

Execution Conditions

PlsdivSetSampling command must be executed before this command.

Filename

PlsdivSetSmoothing.exe

Write Type

String

Read Type

String. However, this command does not return any output parameter.

Write String

This command needs the following input parameters in this sequence.

- ch** Oscilloscope channel. Numeric value, 0 (channel for gate) or 1 (channel for drain).
- smooth_stat** Smoothing function on or off. Numeric value, 0 (off) or 1 (on).
- smooth_num** Number of measurement points used for smoothing. Numeric value, 3 to 4001. The value must be less than the *sampling_num* parameter value set to the PlsdivSetSampling command.

Response

Status code. Numeric value. To read the error message, use PlsdivErrorMessage. If no error is detected by this command execution, 0 is returned.

Remarks

The smoothing function averages the time-series data to reduce variation caused by high-frequency component.

Set appropriate *smooth_num* value while monitoring the waveform. Too much *smooth_num* value will lose the waveform edges, which disturbs accurate results.

PlsdivSetTransTime

This command changes the pulse transition time of the gate voltage. This change is effective after the PlsdivForceVg command is executed and until the next PlsdivSetTransTime command or the PlsdivUninit command is executed. This command execution is optional.

The transition time is defined as the time from the pulse level 10 % point to the 90 % point. See Figure 6-6.

Remarks	Changing this value may cause measurement errors.		
Filename	PlsdivSetTransTime.exe		
Write Type	String		
Read Type	String. However, this command does not return any output parameter.		
Write String	This command needs the following input parameter. <table> <tr> <td>trans_time</td> <td>Transition time, in second. Numeric value, 2 nsec to 200 msec. This value must be less than half of the <i>pulse_width</i> parameter value set to the PlsdivSetPulseWidth command. For the 81101A, minimum value is 5 ns. For the 81150A, minimum value is 2.5 ns when the following conditions are satisfied, or 7.5 ns. <ul style="list-style-type: none"> • Pulse amplitude is 2.5 V or less. • Both pulse base and top are within ± 2.5 V. </td> </tr> </table>	trans_time	Transition time, in second. Numeric value, 2 nsec to 200 msec. This value must be less than half of the <i>pulse_width</i> parameter value set to the PlsdivSetPulseWidth command. For the 81101A, minimum value is 5 ns. For the 81150A, minimum value is 2.5 ns when the following conditions are satisfied, or 7.5 ns. <ul style="list-style-type: none"> • Pulse amplitude is 2.5 V or less. • Both pulse base and top are within ± 2.5 V.
trans_time	Transition time, in second. Numeric value, 2 nsec to 200 msec. This value must be less than half of the <i>pulse_width</i> parameter value set to the PlsdivSetPulseWidth command. For the 81101A, minimum value is 5 ns. For the 81150A, minimum value is 2.5 ns when the following conditions are satisfied, or 7.5 ns. <ul style="list-style-type: none"> • Pulse amplitude is 2.5 V or less. • Both pulse base and top are within ± 2.5 V. 		
Response	Status code. Numeric value. To read the error message, use PlsdivErrorMessage. If no error is detected by this command execution, 0 is returned.		

PlsdivSetVgLevel

This command sets the pulse level and polarity of the gate voltage.

Remarks	Check the pulse waveform on the oscilloscope screen, and adjust the gate pulse level so that the gate pulse and the drain pulse can be monitored.
Filename	PlsdivSetSampling.exe

PLSDIV TIS Commands

PlsdivUninit

Write Type	String
Read Type	String. However, this command does not return any output parameter.
Write String	This command needs the following input parameters in this sequence. vg_high Pulse high level, in V. Numeric value, -4.5 to 4.5. vg_base Pulse base level, in V. Numeric value, -3.0 to 3.0 V. polarity Polarity of pulse. Numeric value, 0 (positive) or 1 (negative). See Figure 6-7.

where, $vg_high > vg_base$ and $55\text{ mV} < |vg_high - vg_base| < 4.5\text{ V}$ must be satisfied.

To use the gate voltage automatic adjustment function, set $|vg_high - vg_base| < 4.0\text{ V}$.

Figure 6-7

Pulse Level and Polarity

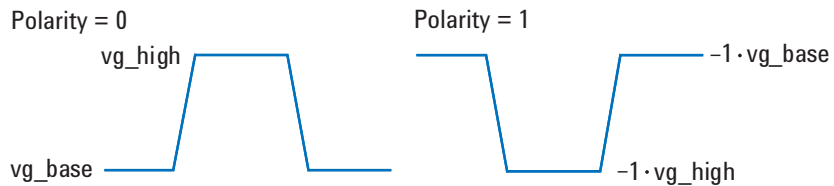

Response	Status code. Numeric value. To read the error message, use PlsdivErrorMessage. If no error is detected by this command execution, 0 is returned.
-----------------	--

PlsdivUninit

This command resets the pulsed IV test system (all instruments) and closes GPIB communication to each instrument.

After executing this command, any Plsdiv commands except for PlsdivInit cannot be executed. So, make sure to execute PlsdivInit before executing any command.

Filename	PlsdivUninit.exe
-----------------	------------------

Response	Status code. Numeric value. To read the error message, use PlsdivErrorMessage. If no error is detected by this command execution, 0 is returned.
-----------------	--

Status Code and Error Messages

This chapter lists the status code and error messages of the pulsed IV solution for Agilent B1500A.

- Table 7-1, “Pulsed IV Library (Plsdiv commands, PLSDIV TIS) Error”
- Table 7-2, “Pulse Generator Driver Error”
- Table 7-3, “Digital Sampling Oscilloscope Driver Error”

If an error occurs, find solutions from error messages and instrument manuals, and solve problems. However, if the problems still remain, perform a self-test.

If the instrument fails in the self-test or the problems still remain, contact your nearest Agilent Technologies Service Center.

To get the latest firmware/software/manuals/support information, go to www.agilent.com and type in B1542A in the Search field at the top of the page.

NOTE

This chapter uses the following conventions.

<system drive>: Drive the pulsed IV system software is installed

<user name>: Windows login account

<program folder>: Following folder

For Windows 7 64 bit version, <system drive>:\Program Files (x86)

For B1500A, Windows 7 32 bit version, and Windows XP,

<system drive>:\Program Files

<data folder>: Following folder

For Windows 7, <system drive>:\Program Data

For Windows XP, <system drive>:\Documents and Settings\All Users\Application Data

<temp folder>: Following folder

For Windows 7, <system drive>:\Users\<user name>\AppData\Local\Temp

For Windows XP,

<system drive>:\Documents and Settings\<user name>\Local Settings\Temp

Table 7-1 Pulsed IV Library (Plsdiv commands, PLSDIV TIS) Error

Status Code Name	Status Code	Error Number	Error Message
SYSPIV_NO_ERROR	0	0	No error.
SYSPIV_ERROR_NULL_PTR	BFFC1001	-4097	NULL pointer was detected. Specify the variable.
SYSPIV_ERROR_RESET_FAILED	BFFC1002	-4098	Reset failed. Reboot instruments.
SYSPIV_ERROR_UNEXPECTED	BFFC1003	-4099	Unexpected error occurred.
SYSPIV_ERROR_DETECTED	BFFC1004	-4100	Any error was detected.
SYSPIV_NO_LAST_COMMA	BFFC1005	-4101	Last comma is not found.
SYSPIV_INV_ASCII_NUMBER	BFFC1006	-4102	Invalid ASCII number was sent.
SYSPIV_DVRPIVDC_ERROR	BFFC1009	-4105	SMU error. See the message on the screen and instrument manual.
SYSPIV_ERROR_PARAMETER1	BFFC1010	-4112	Invalid value for parameter 1.
SYSPIV_ERROR_PARAMETER2	BFFC1011	-4113	Invalid value for parameter 2.
SYSPIV_ERROR_PARAMETER3	BFFC1012	-4114	Invalid value for parameter 3.
SYSPIV_ERROR_PARAMETER4	BFFC1013	-4115	Invalid value for parameter 4.
SYSPIV_ERROR_PARAMETER5	BFFC1014	-4116	Invalid value for parameter 5.
SYSPIV_ERROR_PARAMETER6	BFFC1015	-4117	Invalid value for parameter 6.
SYSPIV_ERROR_PARAMETER7	BFFC1016	-4118	Invalid value for parameter 7.
SYSPIV_ERROR_PARAMETER8	BFFC1017	-4119	Invalid value for parameter 8.
SYSPIV_ERROR_PARAMETER9	BFFC1018	-4120	Invalid value for parameter 9.
SYSPIV_ERROR_PARAMETER10	BFFC1019	-4121	Invalid value for parameter 10.
SYSPIV_ERROR_PARAMETER11	BFFC101A	-4122	Invalid value for parameter 11.
SYSPIV_ERROR_PARAMETER12	BFFC101B	-4123	Invalid value for parameter 12.
SYSPIV_ERROR_PARAMETER13	BFFC101C	-4124	Invalid value for parameter 13.

Status Code and Error Messages

Status Code Name	Status Code	Error Number	Error Message
SYSPIV_ERROR_PARAMETER14	BFFC101D	-4125	Invalid value for parameter 14.
SYSPIV_ERROR_PARAMETER15	BFFC101E	-4126	Invalid value for parameter 15.
SYSPIV_ERROR_PARAMETER16	BFFC101F	-4127	Invalid value for parameter 16.
SYSPIV_ERROR_CPM_PIV_SET_SAMPLING_NOT_COMPLETED	BFFC1020	-4128	PlsdivCaptureMonData: Execute PlsdivSetSampling before this command.
SYSPIV_ERROR_CPM_SAMPLING_NUM_DEFINITION	BFFC1021	-4129	PlsdivCaptureMonData: Define the sampling number in PlsdivSetSampling. Do not set 0.
SYSPIV_ERROR_CPM_MEASURE_ID_NOT_COMPLETED	BFFC1022	-4130	PlsdivCaptureMonData: Execute PlsdivMeasureId before this command.
SYSPIV_ERROR_CPM_SAMPLING_NUM_INCOMPATIBLE	BFFC1023	-4131	PlsdivCaptureMonData: Define the same value as the sampling number specified by PlsdivSetSampling.
SYSPIV_ERROR_CPM_DRAIN_MODE_INVALID	BFFC1024	-4132	PlsdivCaptureMonData: The drain data type must be 0: voltage or 1: current.
SYSPIV_ERROR_CPM_RET_PTR_NULL	BFFC1025	-4133	PlsdivCaptureMonData: Specify the variable used for read_data.
SYSPIV_ERROR_CPS_PIV_SET_SAMPLING_NOT_COMPLETED	BFFC1028	-4136	PlsdivCapturePulseShape: Execute PlsdivSetSampling before this command.
SYSPIV_ERROR_CPS_SAMPLING_NUM_DEFINITION	BFFC1029	-4137	PlsdivCapturePulseShape: Define the sampling number in PlsdivSetSampling. Do not set 0.
SYSPIV_ERROR_CPS_MEASURE_ID_NOT_COMPLETED	BFFC102A	-4138	PlsdivCapturePulseShape: Execute PlsdivMeasureId before this command.

Status Code Name	Status Code	Error Number	Error Message
SYSPIV_ERROR_CPS_SAMPLING_NUM_INCOMPATIBLE	BFFC102B	-4139	PlsdivCapturePulseShape: Define the same value as the sampling number specified by PlsdivSetSampling.
SYSPIV_ERROR_CPS_DRAIN_MODE_INVALID	BFFC102C	-4140	PlsdivCapturePulseShape: The drain data type must be 0 or 1.
SYSPIV_ERROR_CPS_TIME_PTR_NULL	BFFC102D	-4141	PlsdivCapturePulseShape: Specify the variable used for time_val.
SYSPIV_ERROR_CPS_GATE_VAL_PTR_NULL	BFFC102E	-4142	PlsdivCapturePulseShape: Specify the variable used for gate_val.
SYSPIV_ERROR_CPS_DRAIN_VAL_PTR_NULL	BFFC102F	-4143	PlsdivCapturePulseShape: Specify the variable used for drain_val.
SYSPIV_ERROR_CPT_PIV_SET_SAMPLING_NOT_COMPLETED	BFFC1030	-4144	PlsdivCaptureTimeData: Execute PlsdivSetSampling before this command.
SYSPIV_ERROR_CPT_SAMPLING_NUM_DEFINITION	BFFC1031	-4145	PlsdivCaptureTimeData: Define the sampling number in PlsdivSetSampling. Do not set 0.
SYSPIV_ERROR_CPT_MEASURE_ID_NOT_COMPLETED	BFFC1032	-4146	PlsdivCaptureTimeData: Execute PlsdivMeasureId before this command.
SYSPIV_ERROR_CPT_SAMPLING_NUM_INCOMPATIBLE	BFFC1033	-4147	PlsdivCaptureTimeData: Define the same value as the sampling number specified by PlsdivSetSampling.
SYSPIV_ERROR_CPT_TIME_PTR_NULL	BFFC1034	-4148	PlsdivCaptureTimeData: Specify the variable used for read_data.
SYSPIV_ERROR_COVD_PIV_INIT_NOT_COMPLETED	BFFC1038	-4152	PlsdivCutoffVd: Execute PlsdivInit before this command.
SYSPIV_ERROR_COVG_PIV_INIT_NOT_COMPLETED	BFFC103C	-4156	PlsdivCutoffVg: Execute PlsdivInit before this command.

Status Code and Error Messages

Status Code Name	Status Code	Error Number	Error Message
SYSPIV_ERROR_NULL_MESSAGE_PTR	BFFC1040	-4160	PlsdivErrorMessage: Specify the variable used for error message.
SYSPIV_ERROR_NULL_ERR_NUM_PTR	BFFC1041	-4161	PlsdivErrorMessage: Specify the variable used for error number.
SYSPIV_UNKNOWN_ERROR_CODE	BFFC1042	-4162	PlsdivErrorMessage: Unknown error code was detected.
SYSPIV_ERROR_FVD_PIV_INIT_NOT_COMPLETED	BFFC1044	-4164	PlsdivForceVd: Execute PlsdivInit before this command.
SYSPIV_ERROR_FVD_VD_OUT_OF_RANGE	BFFC1045	-4165	PlsdivForceVd: Correct the vd value. It must be $-10\text{ V} \leq \text{vd} \leq 10\text{ V}$.
SYSPIV_ERROR_FVG_PIV_INT_NOT_COMPLETED	BFFC1048	-4168	PlsdivForceVg: Execute PlsdivInit before this command.
SYSPIV_ERROR_FVG_PIV_SET_PULSE_WIDTH_NOT_COMPLETED	BFFC1049	-4169	PlsdivForceVg: Execute PlsdivSetPulseWidth before this command.
SYSPIV_ERROR_FVG_PIV_SET_VG_LEVEL_NOT_COMPLETED	BFFC104A	-4170	PlsdivForceVg: Execute PlsdivSetVgLevel before this command.
SYSPIV_ERROR_FVG_PIV_SET_SMTH_NOT_COMPLETED	BFFC104B	-4171	PlsdivForceVg: Execute PlsdivSetSmoothing before this command.
SYSPIV_ERROR_FVG_VG_MON_NULL	BFFC104C	-4172	PlsdivForceVg: Specify the variable used for vg_mon.
SYSPIV_ERROR_FVG_CONV_STAT_NULL	BFFC104D	-4173	PlsdivForceVg: Specify the variable used for conv_stat.
SYSPIV_ERROR_INIT_INVALID_STAT_CHK_CNN	BFFC1050	-4176	PlsdivInit: The connect check status must be 0: OFF or 1: ON.
SYSPIV_ERROR_INIT_INVALID_STAT_ZERO_CANCEL	BFFC1051	-4177	PlsdivInit: The gate zero status must be 0: OFF or 1: ON.

Status Code Name	Status Code	Error Number	Error Message
SYSPIV_ERROR_INIT_NO_CONFIG_FILE	BFFC1052	-4178	PlsdivInit: sys_plsdiv.cf is not found. Reinstall the pulsed IV software.
SYSPIV_ERROR_INIT_PERMISSION_CONFIG_FILE	BFFC1053	-4179	PlsdivInit: sys_plsdiv.cf permission error. Set read permission for this user.
SYSPIV_ERROR_INIT_AN_ERROR_ON_CONFIG_FILE	BFFC1054	-4180	PlsdivInit: sys_plsdiv.cf open error. Reinstall the pulsed IV software.
SYSPIV_ERROR_INIT_KEYWORD_ON_CONFIG_FILE	BFFC1055	-4181	PlsdivInit: sys_plsdiv.cf keyword error. Reinstall the pulsed IV software.
SYSPIV_ERROR_INIT_NO_PULSE_CONFIG_FILE	BFFC1056	-4182	PlsdivInit: gate_pulse.cf is not found. Reinstall the pulsed IV software.
SYSPIV_ERROR_INIT_PERMISSION_PULSE_CONFIG_FILE	BFFC1057	-4183	PlsdivInit: gate_pulse.cf permission error. Set read permission for this user.
SYSPIV_ERROR_INIT_AN_ERROR_ON_PULSE_CONFIG_FILE	BFFC1058	-4184	PlsdivInit: gate_pulse.cf open error. Reinstall the pulsed IV software.
SYSPIV_ERROR_INIT_KEYWORD_ON_PULSE_CONFIG_FILE	BFFC1059	-4185	PlsdivInit: gate_pulse.cf keyword error. Reinstall the pulsed IV software.
SYSPIV_ERROR_INIT_NO_INIT_FILE	BFFC105A	-4186	PlsdivInit: sys_plsdiv.int is not found. Reinstall the pulsed IV software.
SYSPIV_ERROR_INIT_PERMISSION_INIT_FILE	BFFC105B	-4187	PlsdivInit: sys_plsdiv.int permission error. Set read permission for this user.
SYSPIV_ERROR_INIT_AN_ERROR_ON_INIT_FILE	BFFC105C	-4188	PlsdivInit: sys_plsdiv.int open error. Reinstall the pulsed IV software.
SYSPIV_ERROR_INIT_KEYWORD_ON_INIT_FILE	BFFC105D	-4189	PlsdivInit: sys_plsdiv.int keyword error. Reinstall the pulsed IV software.

Status Code and Error Messages

Status Code Name	Status Code	Error Number	Error Message
SYSPIV_ERROR_INIT_NO_SCOPE_MON_COMP_FILE	BFFC105E	-4190	PlsdivInit: scope_mon.cmp is not found. Reinstall the pulsed IV software.
SYSPIV_ERROR_INIT_PERMISSION_SCOPE_MON_COMP_FILE	BFFC105F	-4191	PlsdivInit: scope_mon.cmp permission error. Set read permission for this user.
SYSPIV_ERROR_INIT_AN_ERROR_ON_SCOPE_MON_COMP_FILE	BFFC1060	-4192	PlsdivInit: scope_mon.cmp open error. Reinstall the pulsed IV software.
SYSPIV_ERROR_INIT_KEYWORD_ON_SCOPE_MON_COMP_FILE	BFFC1061	-4193	PlsdivInit: scope_mon.cmp keyword error. Reinstall the pulsed IV software.
SYSPIV_ERROR_INIT_NO_DIVIDER_COMP_FILE	BFFC1062	-4194	PlsdivInit: divider.cmp is not found. Reinstall the pulsed IV software.
SYSPIV_ERROR_INIT_PERMISSION_DIVIDER_COMP_FILE	BFFC1063	-4195	PlsdivInit: divider.cmp permission error. Set read permission for this user.
SYSPIV_ERROR_INIT_AN_ERROR_ON_DIVIDER_COMP_FILE	BFFC1064	-4196	PlsdivInit: divider.cmp open error. Reinstall the pulsed IV software.
SYSPIV_ERROR_INIT_KEYWORD_ON_DIVIDER_COMP_FILE	BFFC1065	-4197	PlsdivInit: divider.cmp keyword error. Reinstall the pulsed IV software.
SYSPIV_ERROR_INIT_NO_PGU_COMP_FILE	BFFC1066	-4198	PlsdivInit: pgu_output.cmp is not found. Reinstall the pulsed IV software.
SYSPIV_ERROR_INIT_PERMISSION_PGU_COMP_FILE	BFFC1067	-4199	PlsdivInit: pgu_output.cmp permission error. Set read permission for this user.
SYSPIV_ERROR_INIT_AN_ERROR_ON_PGU_COMP_FILE	BFFC1068	-4200	PlsdivInit: pgu_output.cmp open error. Reinstall the pulsed IV software.

Status Code Name	Status Code	Error Number	Error Message
SYSPIV_ERROR_INIT_KEYWORD_ON_PGU_COMP_FILE	BFFC1069	-4201	PlsdivInit: pgu_output.cmp keyword error. Reinstall the pulsed IV software.
SYSPIV_ERROR_INIT_PULSE_PARAMETER_MISMATCH_ON_PGU_COMP_FILE	BFFC106A	-4202	PlsdivInit: pgu_output.cmp pulse parameter mismatch. Reinstall the pulsed IV software.
SYSPIV_ERROR_INIT_NO_DRAIN_COMP_FILE	BFFC106B	-4203	PlsdivInit: drain_trans.cmp is not found. Reinstall the pulsed IV software.
SYSPIV_ERROR_INIT_PERMISSION_DRAIN_COMP_FILE	BFFC106C	-4204	PlsdivInit: drain_trans.cmp permission error. Set read permission for this user.
SYSPIV_ERROR_INIT_AN_ERROR_ON_DRAIN_COMP_FILE	BFFC106D	-4205	PlsdivInit: drain_trans.cmp open error. Reinstall the pulsed IV software.
SYSPIV_ERROR_INIT_KEYWORD_ON_DRAIN_COMP_FILE	BFFC106E	-4206	PlsdivInit: drain_trans.cmp keyword error. Reinstall the pulsed IV software.
SYSPIV_ERROR_INIT_PULSE_PARAMETER_MISMATCH_ON_DRAIN_COMP_FILE	BFFC106F	-4207	PlsdivInit: drain_trans.cmp pulse parameter mismatch. It must be same as the parameter in gate_pulse.cf. Reinstall the pulsed IV software.
SYSPIV_ERROR_INIT_NO_INPUT_Z_FILE	BFFC1070	-4208	PlsdivInit: scope_input_z.cmp is not found. Reinstall the pulsed IV software.
SYSPIV_ERROR_INIT_PERMISSION_INPUT_Z_FILE	BFFC1071	-4209	PlsdivInit: scope_input_z.cmp permission error. Set read permission for this user.
SYSPIV_ERROR_INIT_AN_ERROR_ON_INPUT_Z_FILE	BFFC1072	-4210	PlsdivInit: scope_input_z.cmp open error. Reinstall the pulsed IV software.

Status Code and Error Messages

Status Code Name	Status Code	Error Number	Error Message
SYSPIV_ERROR_INIT_KEYWORD_ON_INPUT_Z_FILE	BFFC1073	-4211	PlsdivInit: scope_input_z.cmp keyword error. Reinstall the pulsed IV software.
SYSPIV_ERROR_INIT_PULSE_PARAMETER_MISMATCH_ON_INPUT_Z_FILE	BFFC1074	-4212	PlsdivInit: scope_input_z.cmp pulse parameter mismatch. It must be same as the parameter in gate_pulse.cf. Reinstall the pulsed IV software.
SYSPIV_ERROR_INIT_NO_EQUIV_Z_FILE	BFFC1075	-4213	PlsdivInit: scope_equiv_z.cmp is not found. Reinstall the pulsed IV software.
SYSPIV_ERROR_INIT_PERMISSION_EQUIV_Z_FILE	BFFC1076	-4214	PlsdivInit: scope_equiv_z.cmp permission error. Set read permission for this user.
SYSPIV_ERROR_INIT_AN_ERROR_ON_EQUIV_Z_FILE	BFFC1077	-4215	PlsdivInit: scope_equiv_z.cmp open error. Reinstall the pulsed IV software.
SYSPIV_ERROR_INIT_KEYWORD_ON_EQUIV_Z_FILE	BFFC1078	-4216	PlsdivInit: scope_equiv_z.cmp keyword error. Reinstall the pulsed IV software.
SYSPIV_ERROR_INIT_PULSE_PARAMETER_MISMATCH_ON_EQUIV_Z_FILE	BFFC1079	-4217	PlsdivInit: scope_equiv_z.cmp pulse parameter mismatch. It must be same as the parameter in gate_pulse.cf. Reinstall the pulsed IV software.
SYSPIV_ERROR_INIT_NO_SYS_DELAY_FILE	BFFC107A	-4218	PlsdivInit: sys_delay.cmp is not found. Reinstall the pulsed IV software.
SYSPIV_ERROR_INIT_PERMISSION_SYS_DELAY_FILE	BFFC107B	-4219	PlsdivInit: sys_delay.cmp permission error. Set read permission for this user.
SYSPIV_ERROR_INIT_AN_ERROR_ON_SYS_DELAY_FILE	BFFC107C	-4220	PlsdivInit: sys_delay.cmp open error. Reinstall the pulsed IV software.

Status Code Name	Status Code	Error Number	Error Message
SYSPIV_ERROR_INIT_KEYWORD_ON_SYS_DELAY_FILE	BFFC107D	-4221	PlsdivInit: sys_delay.cmp keyword error. Reinstall the pulsed IV software.
SYSPIV_ERROR_INIT_CONFIG_MISMATCH	BFFC107E	-4222	PlsdivInit: sys_plsdiv.cf configuration mismatch. Check the system configuration and connect instruments/accessories properly.
SYSPIV_ERROR_INIT_GATE_DIVIDER_NOT_INSTALLED_CORRECTLY	BFFC1080	-4224	PlsdivInit: Gate divider connection error. Connect the divider properly.
SYSPIV_ERROR_INIT_DRAIN_BIAS_T_NOT_INSTALLED_CORRECTLY	BFFC1081	-4225	PlsdivInit: Drain bias-T connection error. Connect the bias-T properly.
SYSPIV_ERROR_MID_PIV_INIT_NOT_COMPLETED	BFFC1088	-4232	PlsdivMeasureId: Execute PlsdivInit before this command.
SYSPIV_ERROR_MID_PIV_SET_AVG_NOT_COMPLETED	BFFC1089	-4233	PlsdivMeasureId: Execute PlsdivSetAveraging before this command.
SYSPIV_ERROR_MID_PIV_FORCE_VD_NOT_COMPLETED	BFFC108A	-4234	PlsdivMeasureId: Execute PlsdivForceVd before this command.
SYSPIV_ERROR_MID_PIV_FORCE_VG_NOT_COMPLETED	BFFC108B	-4235	PlsdivMeasureId: Execute PlsdivForceVg before this command.
SYSPIV_ERROR_MID_INVALID_ID_RANGE_MODE	BFFC108C	-4236	PlsdivMeasureId: The measurement ranging mode must be 0: auto or 1: fixed.
SYSPIV_ERROR_MID_ID_RANGE_OUT_OF_RANGE	BFFC108D	-4237	PlsdivMeasureId: Correct the id_range value. It must be $0 \leq id_range \leq 0.08$.
SYSPIV_ERROR_MID_ID_NULL	BFFC108E	-4238	PlsdivMeasureId: Specify the variable used for id.
SYSPIV_ERROR_MID_VD_SET_NULL	BFFC108F	-4239	PlsdivMeasureId: Specify the variable used for vd_set.

Status Code and Error Messages

Status Code Name	Status Code	Error Number	Error Message
SYSPIV_ERROR_MID_VD_ACT_NULL	BFFC1090	-4240	PlsdivMeasureId: Specify the variable used for vd_act.
SYSPIV_ERROR_MID_CONV_STAT_NULL	BFFC1091	-4241	PlsdivMeasureId: Specify the variable used for conv_stat.
SYSPIV_ERROR_SZC_INVALID_TERMINAL_NUM	BFFC1094	-4244	PlsdivScopeZeroCancel: Terminal must be 0: gate or 1: drain.
SYSPIV_ERROR_SZC_PIV_INIT_NOT_COMPLETED	BFFC1095	-4245	PlsdivScopeZeroCancel: Execute PlsdivInit before this command.
SYSPIV_ERROR_ZSC_NO_SCOPE_MON_COMP_FILE	BFFC1096	-4246	PlsdivScopeZeroCancel: scope_mon.cmp is not found. Reinstall the pulsed IV software.
SYSPIV_ERROR_ZSC_PERMISSION_SCOPE_MON_COMP_FILE	BFFC1097	-4247	PlsdivScopeZeroCancel: scope_mon.cmp permission error. Set read permission for this user.
SYSPIV_ERROR_ZSC_AN_ERROR_ON_SCOPE_MON_COMP_FILE	BFFC1098	-4248	PlsdivScopeZeroCancel: scope_mon.cmp open error. Reinstall the pulsed IV software.
SYSPIV_ERROR_ST_PIV_INIT_NOT_COMPLETED	BFFC109C	-4252	PlsdivSelftest: Execute PlsdivInit before this command.
SYSPIV_ERROR_ST_SMU_SELFTEST_FAILED	BFFC109D	-4253	PlsdivSelftest: SMU self-test failed. See instrument manual.
SYSPIV_ERROR_SAC_ADJ_TERM	BFFC10A0	-4256	PlsdivSetAdjustConf: Terminal must be 0: gate or 1: drain.
SYSPIV_ERROR_SAC_ADJ_LIMIT_ABS	BFFC10A1	-4257	PlsdivSetAdjustConf: Adjustment limit must not be 0.
SYSPIV_ERROR_SAC_ADJ_LIMIT_RATE	BFFC10A2	-4258	PlsdivSetAdjustConf: Adjustment limit ratio must be 0 to 1.
SYSPIV_ERROR_SAC_ADJ_LOOP_MAX	BFFC10A3	-4259	PlsdivSetAdjustConf: Adjustment loop max must be 2 to 256.

Status Code Name	Status Code	Error Number	Error Message
SYSPIV_ERROR_SAC_PIV_INIT_NOT_COMPLETED	BFFC10A4	-4260	PlsdivSetAdjustConf: Execute PlsdivInit before this command.
SYSPIV_ERROR_SAS_ADJ_TERM	BFFC10A8	-4264	PlsdivSetAdjustStat: Terminal must be 0: gate or 1: drain.
SYSPIV_ERROR_SAS_ADJ_STAT	BFFC10A9	-4265	PlsdivSetAdjustStat: Adjustment status must be 0: OFF or 1: ON.
SYSPIV_ERROR_SAS_PIV_INIT_NOT_COMPLETED	BFFC10AA	-4266	PlsdivSetAdjustStat: Execute PlsdivInit before this command.
SYSPIV_ERROR_SA_PIV_INIT_NOT_COMPLETED	BFFC10AC	-4268	PlsdivSetAveraging: Execute PlsdivInit before this command.
SYSPIV_ERROR_SDD_DEVICE_DELAY_OUT_OF_RANGE	BFFC10AE	-4270	PlsdivSetDeviceDelay: device_delay must be -1 us to +1 us.
SYSPIV_ERROR_SDD_PIV_INIT_NOT_COMPLETED	BFFC10AF	-4271	PlsdivSetDeviceDelay: Execute PlsdivInit before this command.
SYSPIV_ERROR_SMM_ID_CAL_COMP_STAT	BFFC10B0	-4272	PlsdivSetMeasMode: id compensation status must be 0: OFF or 1: ON.
SYSPIV_ERROR_SMM_ID_LOSS_COMP_STAT	BFFC10B1	-4273	PlsdivSetMeasMode: id loss compensation status must be 0: OFF or 1: ON.
SYSPIV_ERROR_SMM_VG_MON_COMP_STAT	BFFC10B2	-4274	PlsdivSetMeasMode: vg monitor compensation status must be 0: OFF or 1: ON.
SYSPIV_ERROR_SMM_VD_MON_COMP_STAT	BFFC10B3	-4275	PlsdivSetMeasMode: vd monitor compensation status must be 0: OFF or 1: ON.
SYSPIV_ERROR_SMM_VG_DIV_COMP_STAT	BFFC10B4	-4276	PlsdivSetMeasMode: vd divider compensation status must be 0: OFF or 1: ON.

Status Code and Error Messages

Status Code Name	Status Code	Error Number	Error Message
SYSPIV_ERROR_SMM_PGU_COMP_STAT	BFFC10B5	-4277	PlsdivSetMeasMode: PGU output compensation status must be 0: OFF or 1: ON.
SYSPIV_ERROR_SMM_PIV_INIT_NOT_COMPLETED	BFFC10B6	-4278	PlsdivSetMeasMode: Execute PlsdivInit before this command.
SYSPIV_ERROR_SMT_PIV_INIT_NOT_COMPLETED	BFFC10B7	-4279	PlsdivSetMeasTime: Execute PlsdivInit before this command.
SYSPIV_ERROR_SMT_MEAS_TIME_RATE_OUT_OF_RANGE	BFFC10B8	-4280	PlsdivSetMeasTime: Correct the meas_time value. It must be -1 to 1.
SYSPIV_ERROR_SPW_PULSE_WIDTH_OUT_OF_RANGE	BFFC10BA	-4282	PlsdivSetPulseWidth: Correct the pulse width. It must be 10 ns to 1 us.
SYSPIV_ERROR_SPW_PIV_INIT_NOT_COMPLETED	BFFC10BB	-4283	PlsdivSetPulseWidth: Execute PlsdivInit before this command.
SYSPIV_ERROR_SRR_UPPER_RANGE_RATE_OUT_OF_RANGE	BFFC10C0	-4288	PlsdivSetRangingParm: Limit to move to upper range must be 0.5 to 1.
SYSPIV_ERROR_SRR_LOWER_RANGE_RATE_OUT_OF_RANGE	BFFC10C1	-4289	PlsdivSetRangingParm: Limit to move to lower range must be 0.5 to 1.
SYSPIV_ERROR_SRR_LRR_LARGER_THAN_UPPER	BFFC10C2	-4290	PlsdivSetRangingParm: Upper limit must be greater than the lower limit.
SYSPIV_ERROR_SRR_PIV_INIT_NOT_COMPLETED	BFFC10C3	-4291	PlsdivSetRangingParm: Execute PlsdivInit before this command.
SYSPIV_ERROR_SSMP_PIV_INIT_NOT_COMPLETED	BFFC10C5	-4293	PlsdivSetSampling: Execute PlsdivInit before this command.
SYSPIV_ERROR_SMTH_INVALID_SMOOTH_TERM	BFFC10C8	-4296	PlsdivSetSmoothing: Terminal must be 0: gate or 1: drain.
SYSPIV_ERROR_SMTH_INVALID_SMOOTH_STAT	BFFC10C9	-4297	PlsdivSetSmoothing: Smooth_stat value must be 0: OFF or 1: ON.
SYSPIV_ERROR_SMTH_PIV_INIT_NOT_COMPLETED	BFFC10CA	-4298	PlsdivSetSmoothing: Execute PlsdivInit before this command.

Status Code Name	Status Code	Error Number	Error Message
SYSPIV_SMTH_ERROR_PIV_SET_SAMPLING_NOT_COMPLETED	BFFC10CB	-4299	PlsdivSetSmoothing: Execute PlsdivSetSampling before this command.
SYSPIV_ERROR_SMTH_SMTH_NUM_OUT_OF_RANGE	BFFC10CC	-4300	PlsdivSetSmoothing: Smoothing number must be 3 to 4001.
SYSPIV_ERROR_STT_PIV_INIT_NOT_COMPLETED	BFFC10D0	-4304	PlsdivSetTransTime: Execute PlsdivInit before this command.
SYSPIV_ERROR_STT_INVALID_TRNAS_TIME	BFFC10D1	-4305	PlsdivSetTransTime: The trans_time value must be 2 ns to 200 ms.
SYSPIV_ERROR_SVGL_PULSE_WIDTH_NOT_DEFINED	BFFC10D4	-4308	PlsdivSetVgLevel: Execute PlsdivSetPulseWidth before this command.
SYSPIV_ERROR_SVGL_BASELINE_VOLTAGE_MISMATCH	BFFC10D5	-4309	PlsdivSetVgLevel: Correct the vg_base value. It must be same as the system defined value. Or turn on the gate voltage adjustment function.
SYSPIV_ERROR_SVGL_VG_LEVEL_OUT_OF_RANGE	BFFC10D6	-4310	PlsdivSetVgLevel: vg_high must be -4.5 V to 4.5 V.
SYSPIV_ERROR_SVGL_VG_HIGH_SMALLER_THAN_BASE	BFFC10D7	-4311	PlsdivSetVgLevel: vg_high must be greater than vg_base.
SYSPIV_ERROR_SVGL_VG_AMP_OUT_OF_RANGE	BFFC10D8	-4312	PlsdivSetVgLevel: Gate pulse amplitude $ vg_high - vg_base $ must be > 55 mV and < 4.5 V.
SYSPIV_ERROR_SVGL_INVALID_PULSE_POL	BFFC10D9	-4313	PlsdivSetVgLevel: Polarity of pulse must be 0: positive or 1: negative.
SYSPIV_ERROR_SVGL_SET_VG_FAILED	BFFC10DA	-4314	PlsdivSetVgLevel: Vg setting loop was not converged. Change vg value.
SYSPIV_ERROR_SVGL_VG_BASE_OUT_OF_RANGE	BFFC10DB	-4315	PlsdivSetVgLevel: vg_base must be -3.0 V to 3.0 V.
SYSPIV_ERROR_PUINT_PIV_INIT_NOT_COMPLETED	BFFC10E0	-4320	PlsdivUninit: Enter PlsdivInit before this command.

Status Code and Error Messages

Status Code Name	Status Code	Error Number	Error Message
SYSPIV_ERROR_PUSH_GROBALS_PERMISSION_ON_FILE	BFFC10E1	-4321	PlsdivPushGlobals: Set read permission for the <temp folder>.
SYSPIV_ERROR_PUSH_GROBALS_AN_ERROR_ON_FILE	BFFC10E2	-4322	PlsdivPushGlobals: Delete the ~tmp_global.tmp file and execute PlsdivInit. If the error still remains, reinstall the pulsed IV software.
SYSPIV_ERROR_PULL_GROBALS_PERMISSION_ON_FILE	BFFC10E5	-4325	PlsdivPushGlobals: Set read permission for the <temp folder>.
SYSPIV_ERROR_PULL_GROBALS_AN_ERROR_ON_FILE	BFFC10E6	-4326	PlsdivPushGlobals: Delete the ~tmp_global.tmp file and execute PlsdivInit. If the error still remains, reinstall the pulsed IV software.
PIVCOMP_ERROR_GATE_INPUTZ_OUT_OF_LIMIT	BFFC10E7	-4327	Gate voltage monitor channel: Input impedance is out of the limit. Connect measurement cables properly.
PIVCOMP_ERROR_DRAIN_INPUTZ_OUT_OF_LIMIT	BFFC10E8	-4328	Drain voltage monitor channel: Input impedance is out of the limit. Connect measurement cables properly.
PIVCOMP_ERROR_GATE_CH_GAIN_OUT_OF_LIMIT	BFFC10E9	-4329	Gate voltage monitor channel: Gain is out of the limit. Connect measurement cables properly.
PIVCOMP_ERROR_GATE_CH_OFFSET_OUT_OF_LIMIT	BFFC10EA	-4330	Gate voltage monitor channel: Offset is out of the limit. Connect measurement cables properly.
PIVCOMP_ERROR_DRAIN_CH_GAIN_OUT_OF_LIMIT	BFFC10EB	-4331	Drain voltage monitor channel: Gain is out of the limit. Connect measurement cables properly.
PIVCOMP_ERROR_DRAIN_CH_OFFSET_OUT_OF_LIMIT	BFFC10EC	-4332	Drain voltage monitor channel: Offset is out of the limit. Connect measurement cables properly.

Status Code Name	Status Code	Error Number	Error Message
PIVCOMP_ERROR_GATE_DELAY_OUT_OF_LIMIT	BFFC10ED	-4333	Delay time between trigger and gate pulse is out of the limit. Connect measurement cables properly.
PIVCOMP_ERROR_SYS_DELAY_OUT_OF_LIMIT	BFFC10EE	-4334	Delay time between gate pulse and drain pulse is out of the limit. Connect measurement cables properly.
PIVCOMP_ERROR_DRAIN_TRANS_OUT_OF_LIMIT	BFFC10EF	-4335	Drain voltage compensation factor is out of the limit. Reinstall the system compensation data.
PIVCOMP_ERROR_EQUIV_Z_OUT_OF_LIMIT	BFFC10F0	-4336	Drain current calculation factor is out of the limit. Reinstall the system compensation data.
PIVCOMP_ERROR_PERMISSION_INPUT_Z_FILE	BFFC10F1	-4337	Set read permission for the <data folder>\Agilent\PLSDIV\PLSDIVExe\TISExe\Spara folder, or delete all input_z_chx_yV.s1p files and execute PlsdivInit.
PIVCOMP_ERROR_AN_ERROR_ON_INPUT_Z_FILE	BFFC10F2	-4338	Delete all input_z_chx_yV.s1p files and execute PlsdivInit. If the error still remains, reinstall the pulsed IV software.
PIVCOMP_ERROR_PERMISSION_DRAIN_CABLING_FILE	BFFC10F3	-4339	Set read permission for the <program folder>\Agilent\PLSDIV\PLSDIVExe\TISExe\Spara folder, or delete all drain_cabling.s2p files and execute PlsdivInit.
PIVCOMP_ERROR_AN_ERROR_ON_DRAIN_CABLING_FILE	BFFC10F4	-4340	Delete drain_cabling.s2p files and execute PlsdivInit. If the error still remains, reinstall the pulsed IV software.

Status Code and Error Messages

Status Code Name	Status Code	Error Number	Error Message
PIVCOMP_ERROR_NO_DRAIN_CABLING_FILE	BFFC10F6	-4342	drain_cabling.s2p file was not found. Install the drain setup data before executing this program.
PIVCOMP_ERROR_SYS_DELAY_CONNECTION_INVERTED	BFFC10F7	-4343	Measured delay time of the drain cabling is negative. Check the connection of the DSO for the gate pulse monitoring or drain current measurement.
PIVCOMP_ERROR_INVALID_DCS_TYPE	BFFC10F8	-4344	Defined DCS is not supported. Check the type of DCS.

Table 7-2 Pulse Generator Driver Error

Status Code Name	Status Code	Error Number	Error Message
DVRPGU_NO_ERROR	0	0	No error.
DVRPGU_ERROR_SELF_TEST_PASSED	0	0	Selftest passed.
DVRPGU_ERROR_SELF_CAL_PASSED	0	0	Calibration passed.
DVRPGU_INSTR_ERROR_SYSTEM_ERROR	BFFC0E00	-3584	System error occurred.
DVRPGU_INSTR_ERROR_NULL_PTR	BFFC0E01	-3585	NULL pointer was detected.
DVRPGU_INSTR_ERROR_RESET_FAILED	BFFC0E02	-3586	Reset operation failed. Reboot the instrument.
DVRPGU_INSTR_ERROR_UNEXPECTED	BFFC0E03	-3587	Unexpected error occurred.
DVRPGU_INSTR_ERROR_DETECTED	BFFC0E04	-3588	Instrument error occurred.
DVRPGU_INSTR_NO_LAST_COMMA	BFFC0E05	-3589	Nth comma is not found in IDN string.
DVRPGU_INSTR_INV_ASCII_NUMBER	BFFC0E06	-3590	ASCII to numeric conversion error.
DVRPGU_INSTR_ERROR_PARAMETER1	BFFC0E10	-3600	Invalid value for parameter 1.
DVRPGU_INSTR_ERROR_PARAMETER2	BFFC0E11	-3601	Invalid value for parameter 2.
DVRPGU_INSTR_ERROR_PARAMETER3	BFFC0E12	-3602	Invalid value for parameter 3.
DVRPGU_INSTR_ERROR_PARAMETER4	BFFC0E13	-3603	Invalid value for parameter 4.
DVRPGU_INSTR_ERROR_PARAMETER5	BFFC0E14	-3604	Invalid value for parameter 5.
DVRPGU_INSTR_ERROR_PARAMETER6	BFFC0E15	-3605	Invalid value for parameter 6.
DVRPGU_INSTR_ERROR_PARAMETER7	BFFC0E16	-3606	Invalid value for parameter 7.
DVRPGU_INSTR_ERROR_PARAMETER8	BFFC0E17	-3607	Invalid value for parameter 8.
DVRPGU_INSTR_ERROR_PARAMETER9	BFFC0E18	-3608	Invalid value for parameter 9.
DVRPGU_INSTR_ERROR_PARAMETER10	BFFC0E19	-3609	Invalid value for parameter 10.
DVRPGU_INSTR_ERROR_PARAMETER11	BFFC0E1A	-3610	Invalid value for parameter 11.
DVRPGU_INSTR_ERROR_PARAMETER12	BFFC0E1B	-3611	Invalid value for parameter 12.

Status Code and Error Messages

Status Code Name	Status Code	Error Number	Error Message
DVRPGU_INSTR_ERROR_PARAMETER13	BFFC0E1C	-3612	Invalid value for parameter 13.
DVRPGU_INSTR_ERROR_PARAMETER14	BFFC0E1D	-3613	Invalid value for parameter 14.
DVRPGU_INSTR_ERROR_PARAMETER15	BFFC0E1E	-3614	Invalid value for parameter 15.
DVRPGU_INSTR_ERROR_PARAMETER16	BFFC0E1F	-3615	Invalid value for parameter 16.
DVRPGU_ERROR_NO_CONFIG_FILE	BFFC0E20	-3616	Configuration file is not found. Reinstall the pulsed IV software.
DVRPGU_ERROR_PERMISSION_CONFIG_FILE	BFFC0E21	-3617	Configuration file permission error. Set read permission for this user.
DVRPGU_ERROR_AN_ERROR_ON_CONFIG_FILE	BFFC0E22	-3618	Configuration file open error. Reinstall the pulsed IV software.
DVRPGU_ERROR_KEYWORD_ON_CONFIG_FILE	BFFC0E23	-3619	Configuration file keyword error. Reinstall the pulsed IV software.
DVRPGU_ERROR_GPIB_NUM_ON_CONFIG_FILE	BFFC0E24	-3620	Invalid GPIB description. Reinstall the pulsed IV software.
DVRPGU_ERROR_ADDR_ON_CONFIG_FILE	BFFC0E25	-3621	Invalid BUS address. Reinstall the pulsed IV software.
DVRPGU_ERROR_PGU_TYPE_ON_CONFIG_FILE	BFFC0E26	-3622	Invalid PGU type. Reinstall the pulsed IV software.
DVRPGU_ERROR_CHANNEL_ON_CONFIG_FILE	BFFC0E27	-3623	Invalid channel description. Reinstall the pulsed IV software.
DVRPGU_ERROR_PERIOD_ON_CONFIG_FILE	BFFC0E28	-3624	Invalid period description. Reinstall the pulsed IV software.
DVRPGU_ERROR_WIDTH_ON_CONFIG_FILE	BFFC0E29	-3625	Invalid width description. Reinstall the pulsed IV software.
DVRPGU_ERROR_TRANSITION_ON_CONFIG_FILE	BFFC0E2A	-3626	Invalid transition description. Reinstall the pulsed IV software.
DVRPGU_ERROR_AMP_ON_CONFIG_FILE	BFFC0E2B	-3627	Invalid amplitude description. Reinstall the pulsed IV software.

Status Code Name	Status Code	Error Number	Error Message
DVRPGU_ERROR_OFFSET_ON_CONFIG_FILE	BFFC0E2C	-3628	Invalid offset description. Reinstall the pulsed IV software.
DVRPGU_ERROR_INT_IMP_ON_CONFIG_FILE	BFFC0E2D	-3629	Invalid internal impedance description. Reinstall the pulsed IV software.
DVRPGU_ERROR_EXT_IMP_ON_CONFIG_FILE	BFFC0E2E	-3630	Invalid external impedance description. Reinstall the pulsed IV software.
DVRPGU_ERROR_PGU_TYPE_NOT_MATCH	BFFC0E30	-3632	Instrument IDN does not match. Use the supported instrument.
DVRPGU_ERROR_CH_NOT_AVAILABLE	BFFC0E31	-3633	Specified channel is not installed. Use the channel installed.
DVRPGU_ERROR_DEVICE_IS_BUSY	BFFC0E32	-3634	Device is busy. Reset or reboot the instrument.
DVRPGU_ERROR_DEVICE_NOT_OPENED	BFFC0E33	-3635	Device is not ready. Connect the GPIB cable properly.
DVRPGU_ERROR_SELF_TEST_FAILED	BFFC0E34	-3636	Selftest failed.
DVRPGU_ERROR_SELF_CAL_FAILED	BFFC0E35	-3637	Calibration failed.
DVRPGU_ERROR_PERIOD_TOO_LONG	BFFC0E40	-3648	Period value must be ≤ 999.5 s or width +3.03 ns.
DVRPGU_ERROR_PERIOD_TOO_SHORT	BFFC0E41	-3649	Period must be ≥ 6.06 ns.
DVRPGU_ERROR_WIDTH_TOO_LONG	BFFC0E42	-3650	Width value must be ≤ 999 s.
DVRPGU_ERROR_WIDTH_TOO_SHORT	BFFC0E43	-3651	Width must be ≥ 3.03 ns.
DVRPGU_ERROR_TRANSITION_TOO_LONG	BFFC0E44	-3652	Transition time must be ≤ 200 ms or width/2.
DVRPGU_ERROR_TRANSITION_TOO_SHORT	BFFC0E45	-3653	Transition time must be ≥ 2 ns.
DVRPGU_ERROR_AMP_TOO_LARGE	BFFC0E46	-3654	Amplitude must be ≤ 10 V for 50 ohm system or 20 V for other cases.
DVRPGU_ERROR_AMP_TOO_SMALL	BFFC0E47	-3655	Amplitude must be ≥ 100 mV for 50 ohm system or 200 mV for other cases.

Status Code and Error Messages

Status Code Name	Status Code	Error Number	Error Message
DVRPGU_ERROR_OFFSET_TOO_LARGE	BFFC0E48	-3656	Offset value must be $\leq +10$ V.
DVRPGU_ERROR_OFFSET_TOO_SMALL	BFFC0E49	-3657	Offset value must be ≥ -10 V.
DVRPGU_ERROR_INT_IMP_INVALID	BFFC0E4A	-3658	Internal impedance must be 50 ohm or 1 Mohm.
DVRPGU_ERROR_EXT_IMP_INVALID	BFFC0E4B	-3659	External impedance must be 50 ohm to 1 Mohm.

Table 7-3 Digital Sampling Oscilloscope Driver Error

Status Code Name	Status Code	Error Number	Error Message
DVRSCOPE_NO_ERROR	0	0	No error.
DVRSCOPE_ERROR_SELF_TEST_PASSED	0	0	Selftest passed.
DVRSCOPE_VI_ERROR_SYSTEM_ERROR	BFFC0F00	-3840	System error occurred.
DVRSCOPE_INSTR_ERROR_NULL_PTR	BFFC0F01	-3841	NULL pointer was detected.
DVRSCOPE_INSTR_ERROR_RESET_FAILED	BFFC0F02	-3842	Reset operation failed. Reboot the instrument.
DVRSCOPE_INSTR_ERROR_UNEXPECTED	BFFC0F03	-3843	Unexpected error occurred.
DVRSCOPE_INSTR_ERROR_DETECTED	BFFC0F04	-3844	Instrument error occurred.
DVRSCOPE_INSTR_NO_LAST_COMMA	BFFC0F05	-3845	Nth comma is not found in IDN string.
DVRSCOPE_INSTR_INV_ASCII_NUMBER	BFFC0F06	-3846	ASCII to numeric conversion error.
DVRSCOPE_INSTR_ERROR_PARAMETER1	BFFC0F10	-3856	Invalid value for parameter 1.
DVRSCOPE_INSTR_ERROR_PARAMETER2	BFFC0F11	-3857	Invalid value for parameter 2.
DVRSCOPE_INSTR_ERROR_PARAMETER3	BFFC0F12	-3858	Invalid value for parameter 3.
DVRSCOPE_INSTR_ERROR_PARAMETER4	BFFC0F13	-3859	Invalid value for parameter 4.
DVRSCOPE_INSTR_ERROR_PARAMETER5	BFFC0F14	-3860	Invalid value for parameter 5.
DVRSCOPE_INSTR_ERROR_PARAMETER6	BFFC0F15	-3861	Invalid value for parameter 6.
DVRSCOPE_INSTR_ERROR_PARAMETER7	BFFC0F16	-3862	Invalid value for parameter 7.
DVRSCOPE_INSTR_ERROR_PARAMETER8	BFFC0F17	-3863	Invalid value for parameter 8.
DVRSCOPE_INSTR_ERROR_PARAMETER9	BFFC0F18	-3864	Invalid value for parameter 9.
DVRSCOPE_INSTR_ERROR_PARAMETER10	BFFC0F19	-3865	Invalid value for parameter 10.
DVRSCOPE_INSTR_ERROR_PARAMETER11	BFFC0F1A	-3866	Invalid value for parameter 11.
DVRSCOPE_INSTR_ERROR_PARAMETER12	BFFC0F1B	-3867	Invalid value for parameter 12.
DVRSCOPE_INSTR_ERROR_PARAMETER13	BFFC0F1C	-3868	Invalid value for parameter 13.

Status Code and Error Messages

Status Code Name	Status Code	Error Number	Error Message
DVRSCOPE_INSTR_ERROR_PARAMETER14	BFFC0F1D	-3869	Invalid value for parameter 14.
DVRSCOPE_INSTR_ERROR_PARAMETER15	BFFC0F1E	-3870	Invalid value for parameter 15.
DVRSCOPE_INSTR_ERROR_PARAMETER16	BFFC0F1F	-3871	Invalid value for parameter 16.
DVRSCOPE_ERROR_NO_CONFIG_FILE	BFFC0F20	-3872	Configuration file is not found. Reinstall the pulsed IV software.
DVRSCOPE_ERROR_PERMISSION_CONFIG_FILE	BFFC0F21	-3873	Configuration file permission error. Set read permission for this user.
DVRSCOPE_ERROR_AN_ERROR_ON_CONFIG_FILE	BFFC0F22	-3874	Configuration file open error. Reinstall the pulsed IV software.
DVRSCOPE_ERROR_KEYWORD_ON_CONFIG_FILE	BFFC0F23	-3875	Configuration file keyword error. Reinstall the pulsed IV software.
DVRSCOPE_ERROR_GPIB_NUM_ON_CONFIG_FILE	BFFC0F24	-3876	Invalid GPIB description. Reinstall the pulsed IV software.
DVRSCOPE_ERROR_ADDR_ON_CONFIG_FILE	BFFC0F25	-3877	Invalid BUS address. Reinstall the pulsed IV software.
DVRSCOPE_ERROR_SCOPE_TYPE_ON_CONFIG_FILE	BFFC0F26	-3878	Invalid SCOPE type. Use the supported instrument.
DVRSCOPE_ERROR_SCOPE_TYPE_NOT_MATCH	BFFC0F30	-3888	Instrument IDN does not match. Use the supported instrument.
DVRSCOPE_ERROR_DEVICE_IS_BUSY	BFFC0F31	-3889	Device is busy. Reset or reboot the instrument.
DVRSCOPE_ERROR_DEVICE_NOT_OPENED	BFFC0F32	-3890	Device is not ready. Connect the GPIB cable properly.
DVRSCOPE_ERROR_SELF_TEST_FAILED	BFFC0F33	-3891	Selftest failed.
DVRSCOPE_ERROR_SOURCE_NAME	BFFC0F40	-3904	Invalid source name. The source name must be CHANNEL or FUNCTION.
DVRSCOPE_ERROR_CH_NUMBER	BFFC0F41	-3905	Channel number must be 1 to 4, or 1 to the number of channels installed.

Status Code Name	Status Code	Error Number	Error Message
DVRSCOPE_ERROR_DISP_STAT	BFFC0F42	-3906	Display status must be ON or OFF.
DVRSCOPE_ERROR_SWEEP_TIMEOUT	BFFC0F43	-3907	Connect trigger input cable properly or change timeout value.
DVRSCOPE_ERROR_MARKER_TYPE	BFFC0F44	-3908	Marker name must be A or B.
DVRSCOPE_ERROR_MARKER_POS	BFFC0F45	-3909	Change time value to display the marker in this time frame.
DVRSCOPE_ERROR_SAMPLING_RATE	BFFC0F46	-3910	Sampling rate must be ≤ 20 GSa/s.
DVRSCOPE_ERROR_SAMPLING_NUMBER	BFFC0F47	-3911	Sampling number must be < 262144 .
DVRSCOPE_ERROR_AVERAGING	BFFC0F48	-3912	Averaging number must be 1 to 4095.
DVRSCOPE_ERROR_SMOOTHING	BFFC0F49	-3913	Smoothing number must be less than the sampling number.
DVRSCOPE_ERROR_TIME_SCALE	BFFC0F4A	-3914	Time scale must be 5 ps to 20 s.
DVRSCOPE_ERROR_TIME_OFFSET	BFFC0F4B	-3915	Horizontal offset value must be $-4*\text{scale}$ to $+4*\text{scale}$.
DVRSCOPE_ERROR_VSCALE	BFFC0F4C	-3916	Voltage scale must be 1 mV to 1 V in 1-2-5 step.
DVRSCOPE_ERROR_VOFFSET	BFFC0F4D	-3917	Change vertical offset to display the waveform in this screen.
DVRSCOPE_ERROR_TRIGGER_SOURCE	BFFC0F4E	-3918	Trigger source name must be 1, 2, 3, 4, AUX, or LINE.
DVRSCOPE_ERROR_TRIGGER_SLOPE	BFFC0F4F	-3919	Trigger slope must be POSITIVE or NEGATIVE.
DVRSCOPE_ERROR_TRIGGER_SWEEP	BFFC0F50	-3920	Sweep mode must be AUTO, TRIGGERED, or SINGLE.
DVRSCOPE_ERROR_TRIGGER_SENS	BFFC0F51	-3921	Trigger sensitivity must be LOW or HIGH.

Status Code and Error Messages

Status Code Name	Status Code	Error Number	Error Message
DVRSCOPE_ERROR_TRIGGER_LEVEL	BFFC0F52	-3922	Trigger level must not exceed the displayed scale. Or it must be -5 to +5 V for the external trigger source.
DVRSCOPE_ERROR_TRIGGER_SOURCE_INVALID	BFFC0F53	-3923	Invalid trigger configuration. Not available for the LINE trigger source.
DVRSCOPE_ERROR_SWEEP_TIME_OUT	BFFC0F54	-3924	Change timeout value.
DVRSCOPE_ERROR_SKEW_VAL	BFFC0F55	-3925	Skew value must be -50 us to +150 us (-25 us to +25 us for 80000B series).
DVRSCOPE_ERROR_THRESHOLD_TYPE	BFFC0F56	-3926	Threshold type must be UPPER, MIDDLE, or LOW.
DVRSCOPE_ERROR_SLOPE_TYPE	BFFC0F57	-3927	Slope type must be + or -.
DVRSCOPE_ERROR_OCCURANCE_VAL	BFFC0F58	-3928	Number of occurrences must be 1 to 65534.